

**Be sure you start your engine on those cold winter mornings. Install a 120VAC plug-in pre-heater for overnight cold weather elimination of fuel wax**

The 120VAC Watt pre-heater warms fuel when your truck is sitting and freezing on those cold winter nights. Warm fuel won't 'wax' and plug up filters.

DAVCO 120VAC pre-heater plugs into the same power outlet you use for engine block heaters. Overnight, the pre-heater keeps filter-clogging wax from forming-without overheating the fuel. If your truck already has block heaters or engine heaters which connect to 120VAC plugs, you may be able to wire the DAVCO pre-heater into that same wiring harness using "Y" cord P/N 102015.

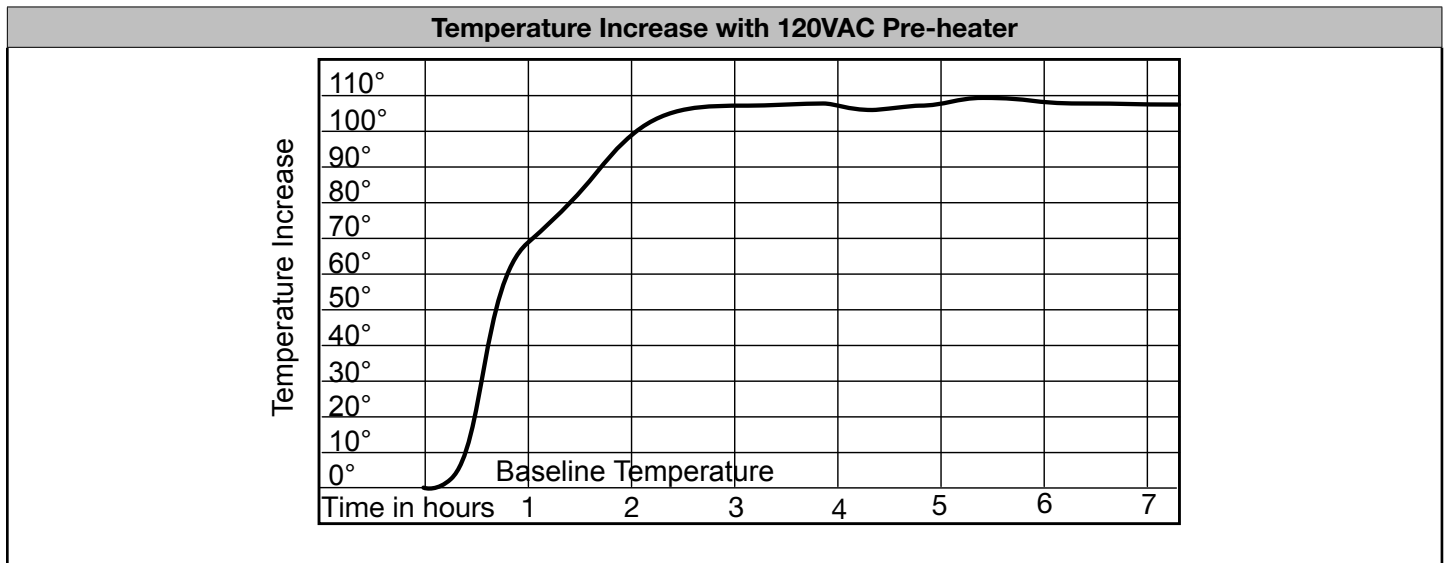

120VAC Pre-heater - Service Parts		
120VAC Pre-heater	102145	
120VAC "Y" Cord	102015	
120VAC Straight Cord	101868	

### Fuel Pro 382 Installation

The Fuel Pro 382 120VAC electric pre-heater is installed in the bottom plate of the fuel processor.

The drawing reflects installation in fluid heated configuration. Pre-heaters can also be installed in bottom plates without fluid heat.

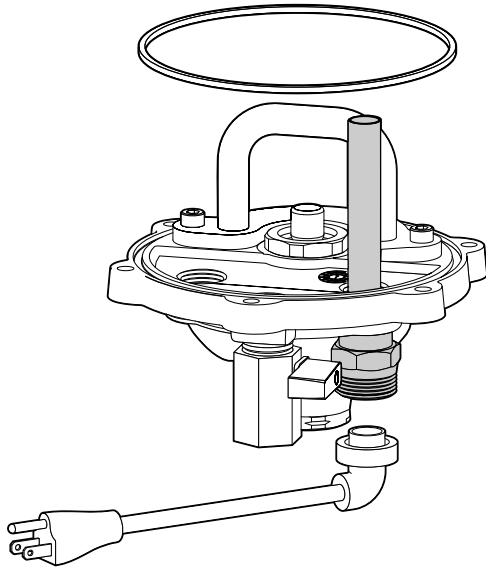

### Fuel Pro 483 Installation

The Fuel Pro 483 120VAC electric pre-heater is installed in the side of the fuel processor.

**Note:** The drawing below reflects the left side Fuel In/Fuel Out configuration. Fuel In is also available on the right side.

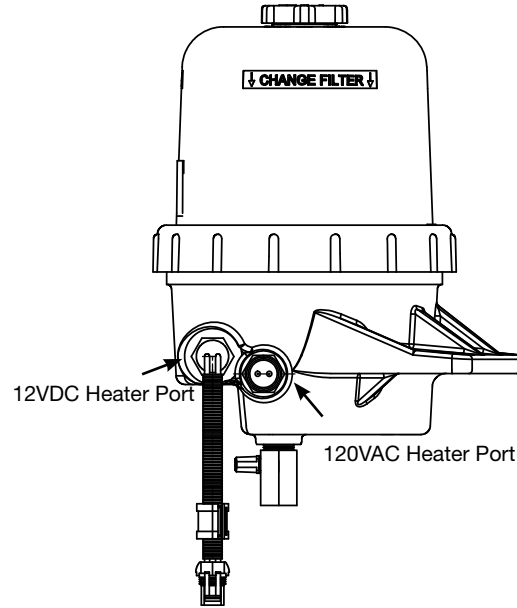

### ⚠ Warning

- **Scalding hazard:** When diesel fuel is circulated through an operating engine, it can become very hot. Allow the engine and fuel to cool to ambient temperature before replacing the fuel filter or performing service operations which could result in spillage of fuel from the fuel system.
- Do not allow fuel to come in contact with eyes or unprotected skin. Protective equipment (gloves and eye protection) should be worn.

### Installation

**Step 1:** Open the vent cap and the drain valve. Drain all the fuel from the Fuel Pro. The fuel can be reused after the pre-heater is installed. If the fuel is not reused, dispose of it in an environmentally safe way. Close the drain.

**Step 2:** Remove the pipe plug in the Fuel Pro base plate.

**Step 3:** Apply liquid thread sealant to the pre-heater threads and install into the Fuel Pro base on the Fuel Pro 382 or the side heater port on the Fuel Pro 483. Tighten to 15-30 ft-lbs.

**Step 4:** Connect the wire harness to the heater and route the harness to a location where it can easily be plugged into a 120VAC outlet.

**Step 5:** Pour fuel into the Fuel Pro to one inch below the top of the filter element. Reinstall the vent cap and tighten.

**Step 6:** Start the engine. When the lubrication system reaches its normal operating pressure, increase engine speed to high idle for one to two minutes. To purge the air, loosen the vent cap until the fuel level drops to just above the collar. Tighten the vent cap.