

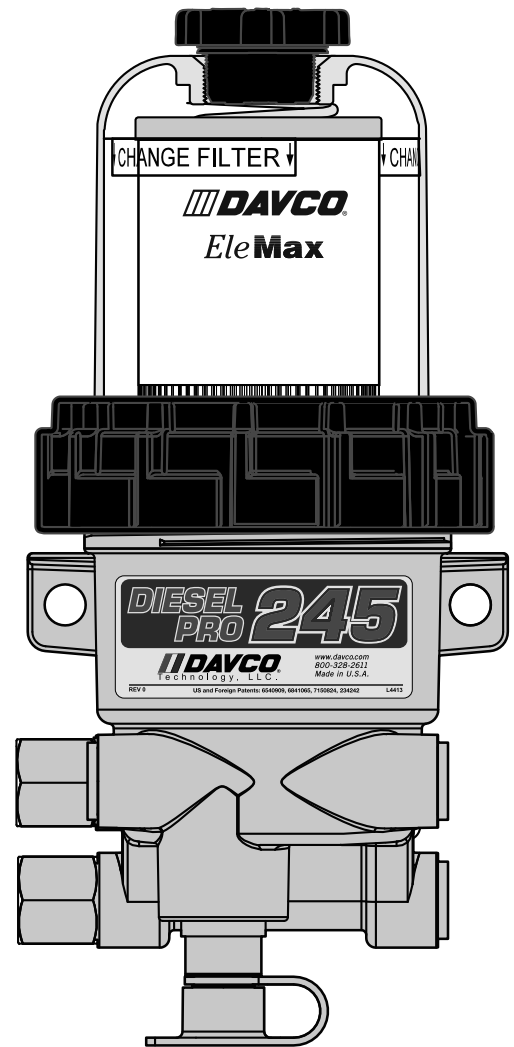

A Clarience Technologies Company

TABLE OF CONTENTS

Applications, Models, and Options... 1
How it Works... 1
"SEEING IS BELIEVING"®... 2
Dimensions and Specifications... 3
Important Safety Precautions... 4
Installation Instructions... 5
120VAC Overnight Heater Installation... 6
Water-in-Fuel Sensor (WIF) Installation... 6
12VDC/24VDC Pre-heater Installation... 7
Primer Pump Installation... 8
Visual Diagnostics - Air vs. Vapor Bubbles... 9
Diagnostic Procedures - Air Leaks... 10
Visual Diagnostics with Clear Cover... 11
Diagnostic Procedures - Check Valve and Pre-heater Testing... 12
Filter Change Procedure... 13
Preventative Maintenance... 14
Service Part Numbers... 15
Warranty Policy... 18
Parts Return Policy... 19



FOR UPDATED INFORMATION, VISIT WWW.DAVCO.COM

DIESEL PRO® 245
TECHNICAL MANUAL

APPLICATIONS, MODELS, AND OPTIONS

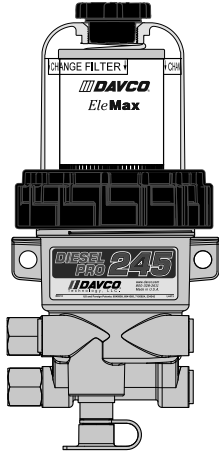

Applications

2017 engine models:

- Detroit DD5 and DD8
- Cummins ISB and ISL

Meets/Exceeds 2017 engine manufacturer's stringent water separation requirements

Models and Options

- Base Model - Unheated
- Electric Pre-heaters
 - 12VDC, 24VDC Pre-heater
 - or 120VAC Overnight heater
- Water-In-Fuel (WIF) Sensor
- Primer pump

HOW IT WORKS

- Fuel from the tank enters the Diesel Pro body (suction side of the fuel system).
- Large contaminants and “free” water are separated from the fuel and remain in the body.
- Fuel rises into the clear cover.
- Contaminants and emulsified water are captured by the filter media.
- Fuel level continues to rise to maintain a fuel path through the clean filter media with low restriction.
- Clean, water-free fuel exits the Diesel Pro and flows to the engine fuel injection system.

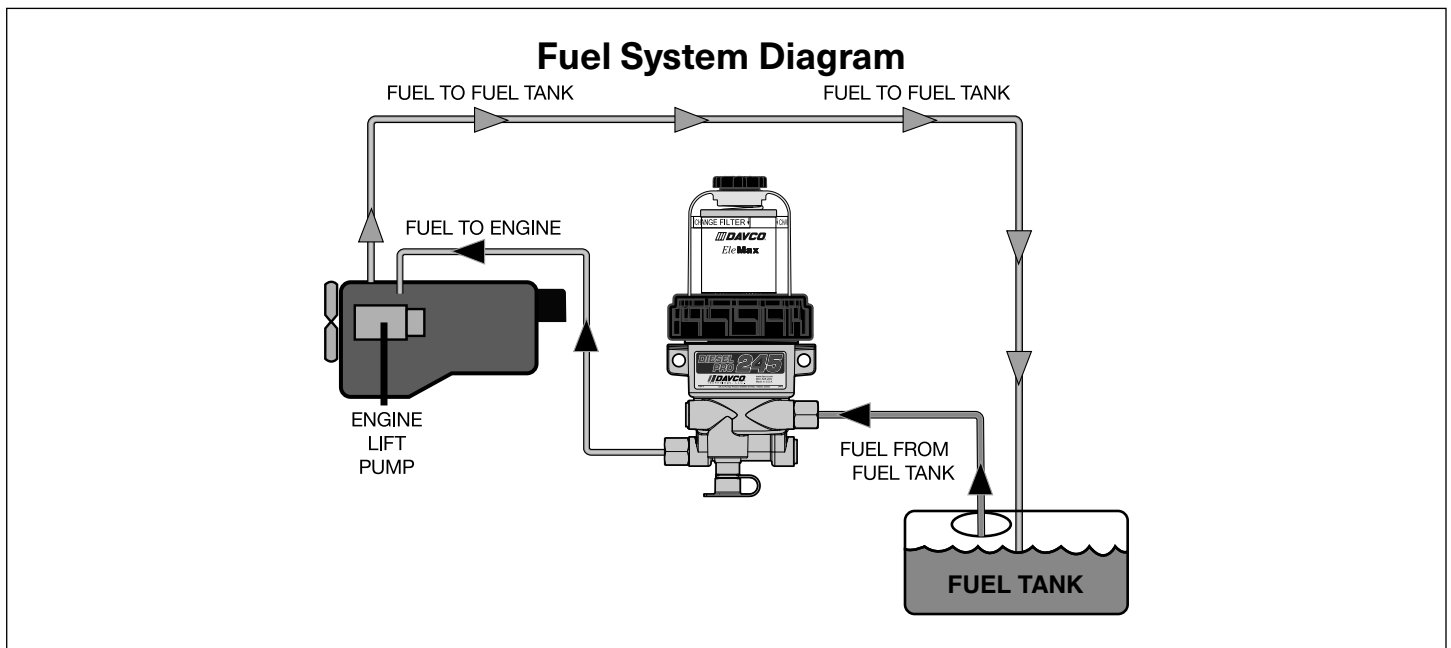

“SEEING IS BELIEVING”®

See when NOT to change the fuel filter.

See the condition of the fuel. Seeing what collects on the filter media or what’s happening inside the clear cover can help diagnose many fuel and mechanical conditions.

“Filter on Top” configuration. Water and debris removed from the fuel falls to the lower chamber and stays away from the filter media resulting in longer filter life.

Built in protection when priming the fuel filter. Unfiltered fuel is kept on the “dirty” side of the filter media during priming ensuring only clean fuel reaches the engine.

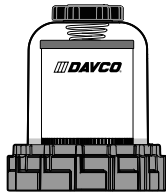

When new, the fuel level in the filter will be very low with minimal restriction. As the filter is used, contaminants collect on the filter from the bottom up. Fuel rises on the filter indicating remaining filter life.



Fuel level increases in clear cover. As contaminants collect on the filter, the fuel rises to a non-contaminated section of the filter, providing optimal filtration while maintaining lowest restriction.

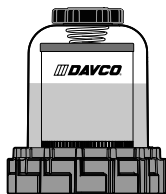

Fuel level at filter wrap level. Even though the fuel level is now more than half of the filter element, the fuel is still flowing through clean media at minimal restriction levels. The filter still has significant life remaining.



The filter element is now completely covered by fuel. At this point, all of the media’s surface area is utilized. Restriction is increasing and the filter element should be changed at the next scheduled maintenance interval.

DIMENSIONS AND SPECIFICATIONS

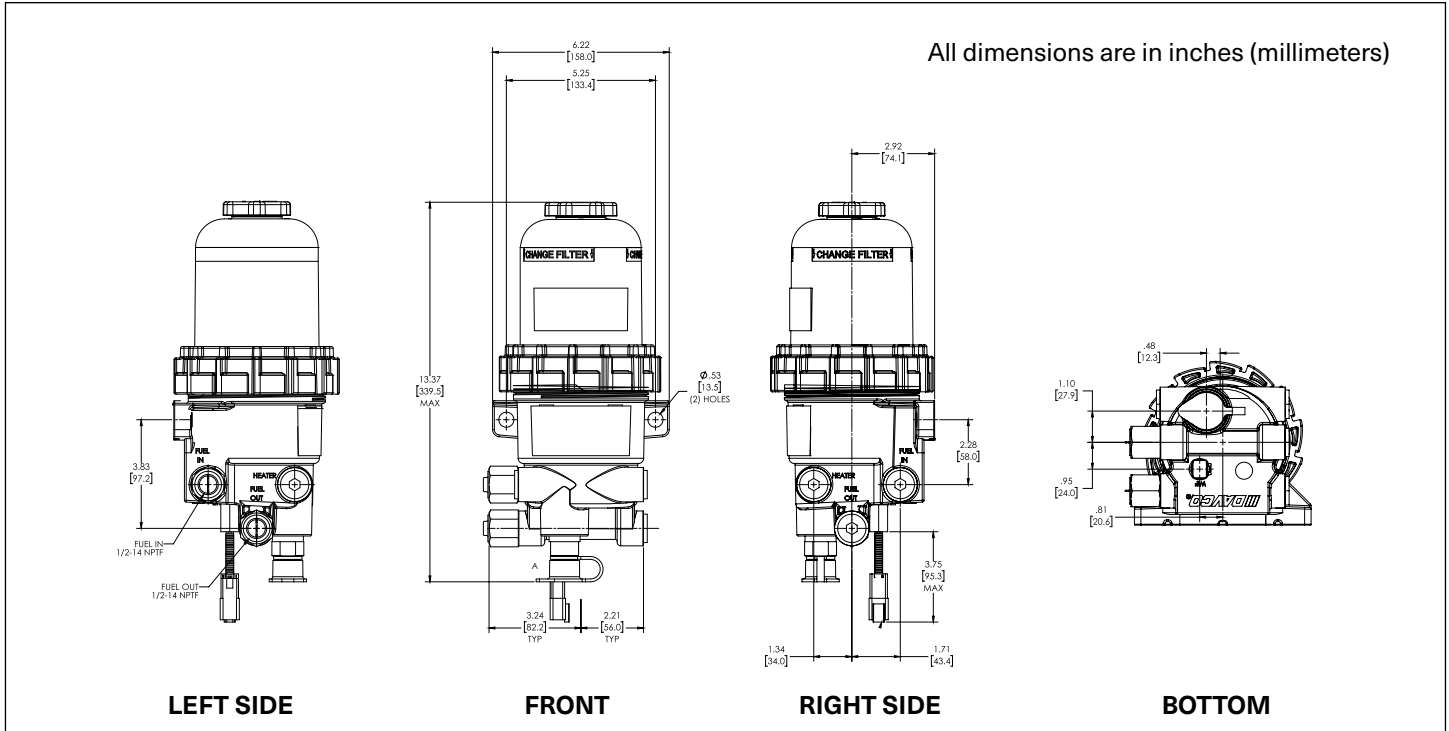

| SPECIFICATIONS | |
|------------------------------|--------------------------|
| Height Overall | 13.37 in (339.5 mm) |
| Depth Overall | 5.84 in (148.3 mm) |
| Width, max. | 6.2 in (158.0 mm) |
| Mount Bracket Centers | 5.25 in (133.4 mm) |
| Weight, dry | 7.5-8.5 lbs |
| Fuel In Connection | ½"-14 NPTF or ⅜"-14 NPTF |
| Fuel Out Connection | ½"-14 NPTF or ⅜"-14 NPTF |
| Filter Service Clearance Min | 3.5" (88.9 mm) |
| Max Fuel Flow | 60 gph |
| Pre-heater | 12VDC, 24VDC |

| FILTRATION PERFORMANCE AT 55 GPH | |
|---|------|
| Micron | 8 |
| Coarse water removal (%) | >98% |
| Emulsified water removal (%) (new filter) | >93% |
| % Emulsified water removal (end of life filter) | >50% |

| FILTRATION PERFORMANCE AT 55 GPH | |
|----------------------------------|-----|
| Dirt holding capacity (grams) | 104 |

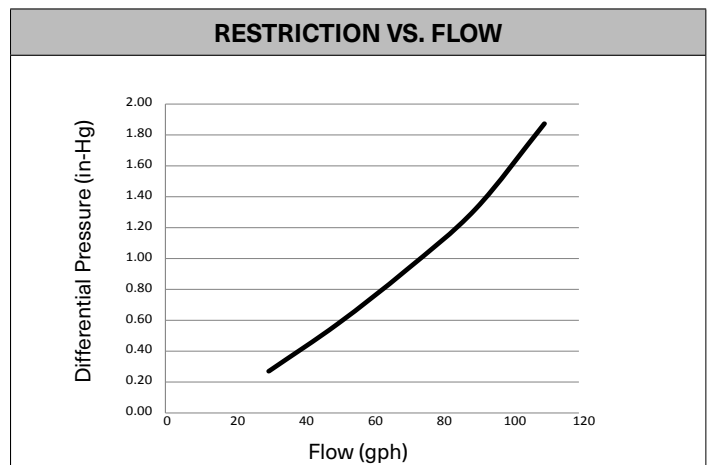

⚠ IMPORTANT SAFETY PRECAUTIONS

General Safety Precautions

- **FOR USE WITH DIESEL FUEL ONLY**
- To avoid serious injury or death, follow the safety information in this document.
- Keep this manual. If you need to replace the manual, call customer service at 800-328-2611 or visit www.davco.com for a replacement.
- Refer to appropriate regulations for environmental and workplace safety rules.

WARNING: To prevent personal injury

- **Scalding hazard:** When diesel fuel is circulated through an operating engine, it can become very hot. Do not allow fuel to come in contact with eyes or unprotected skin. Allow the engine and fuel to cool to ambient temperature before replacing the fuel filter or performing service operations which could result in spillage of fuel from the fuel system.
- **Fire Prevention:** Heated fuel can form combustible vapor mixtures in the area around the fuel source. To eliminate the potential for fire, keep open flames, sparks or other potential ignition sources away from the work area. Do not smoke during filter replacement or service operations.
- **Inhalation Precaution:** Always perform engine or vehicle fuel system maintenance in a well ventilated area that is kept free of bystanders.
- The ignition key must be in the **off** position, unless otherwise directed. To avoid unintentional engine startup, use a lockout key and/or signage to alert personnel that work is being performed.
- Do not energize the pre-heater outside of the Diesel Pro. It can become very hot.

Government Regulations

- Engine fluids (oil, fuel, and coolant) may be a hazard to human health and the environment. Handle all fluids and other contaminated materials (such as filters and rags) in accordance with applicable regulations. Recycle or dispose of engine fluids, filters, and other contaminated materials according to applicable regulations.

INSTALLATION INSTRUCTIONS

Installation Location

The Diesel Pro must be installed between the fuel tank and the fuel transfer pump.

Mounting the Diesel Pro

Mount the Diesel Pro keeping the following points in mind:

- **Do not install the Diesel Pro directly on the engine.**
 - Mount vertically with the cover and element pointing up.
 - Make sure there is enough top and side clearance for the cover to be conveniently removed for filter replacement (3.5" minimum).
 - The Diesel Pro **MUST** be installed so that the Filter Element is above the "FULL" level of the fuel tank. If mounted below full tank level, a shut off valve will be required at the inlet to allow filter changes without overflow of fuel.
1. With the engine shut down and at ambient temperature, close the fuel shutoff valve (if equipped) and place a suitable container under the fuel filters.
 2. Remove the primary fuel filter element assembly, sediment, and/or water separator. Drain the used element and dispose of it in an environmentally responsible manner, according to state and/or federal (EPA) recommendations. The fuel can be returned to the tank.
 3. Mount the Diesel Pro in the desired location using 3/8" Grade 8 bolts.

Fuel Line Routing

To minimize fuel system restriction, observe the following guidelines when plumbing the fuel system:

- Keep the fuel line routing as smooth as possible with no low-hanging loops which can trap water.
 - Use 90° elbows only when necessary.
 - If the fuel hoses are cut to length on the job, be sure that the inner liner of the fuel hose is not cut by the fitting, which can cause check valve performance issues. Make sure hoses are clean and free of debris before installing.
 - To avoid damaging the aluminum Diesel Pro body, do not over-tighten fuel lines or fuel line fittings.
1. Route the fuel supply line from the pick up on the fuel tank to the Diesel Pro inlet (labeled "Fuel In").
 2. Route the fuel outlet line from the Diesel Pro outlet (labeled "Fuel Out") to the inlet of the fuel pump.

The inlet and outlet fittings can be moved from side to side depending on the applications needs. (Example : FUEL IN right and FUEL OUT right,) Be sure to use only ONE INLET and ONE OUTLET port per installation.

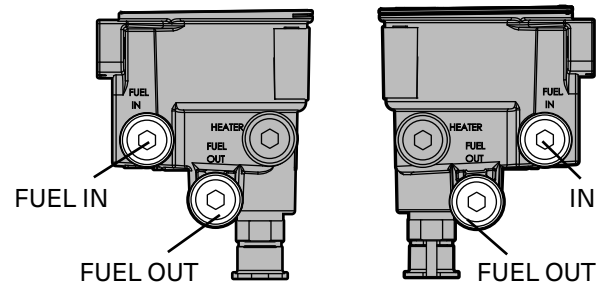

Painting Precautions

The collar/cover joint and threads are designed to be free of paint in order to function properly. The cover and collar assembly must be completely masked off if the Diesel Pro is to be painted.

Priming the Fuel System

1. Check to make sure the drain valve at the base of the Diesel Pro is closed.
2. Remove the vent cap from the top of the clear cover. Fill the Diesel Pro full with clean fuel. Re-install the vent cap. Tighten the vent cap by hand until it clicks.
3. Start the engine. When the lubrication system reaches its normal operating pressure, increase engine RPM to high idle for one to two minutes. After the air is purged loosen the vent cap until the fuel level lowers to just above the collar. Tighten the vent cap by hand until it clicks.

The clear filter cover will not fill completely during engine operation. It will gradually fill over time and the fuel level will rise as the filter becomes contaminated.

120VAC OVERNIGHT HEATER INSTALLATION

The Diesel Pro can have **either** a 12/24VDC Pre-heater **or** an 120VAC Overnight Heater installed. It is not designed for two heaters to be installed into the housing.

1. Open the vent cap. Open the drain valve by turning one to one and a half revolutions. Drain the Diesel Pro completely. Close the drain valve.
2. Remove the pipe plug from the heater port.
3. Apply liquid thread sealant to the heater threads and install into the 120VAC overnight heater port on the Diesel Pro. Tighten to 15-30 ft-lbs.
4. Connect the wire harness to the heater and route the harness to a location where it can easily be plugged into a 120VAC outlet.
5. Prime the Diesel Pro (see page 5) and check for leaks.

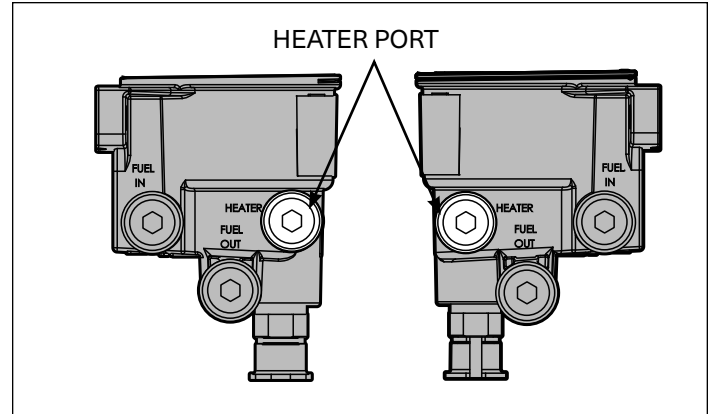

WATER-IN-FUEL SENSOR (WIF) INSTALLATION

1. Open the vent cap. Open the drain valve by turning one to one and a half revolutions. Drain the Diesel Pro completely. Close the drain valve.
2. Install WIF into WIF port. Torque to 20-24 in-lbs.
3. Prime the Diesel Pro (see page 5) and check for leaks.

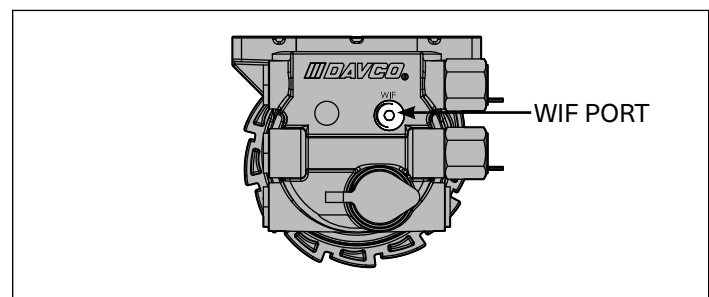

12VDC/24VDC PRE-HEATER INSTALLATION

1. Open the vent cap. Open the drain valve by turning one to one and a half revolutions. Drain the Diesel Pro completely. Close the drain valve.
2. Remove the plug in pre-heater port.
3. Apply liquid thread sealant to the pre-heater threads and install into the bottom plate. Tighten to 15-30 ft-lbs.
4. Connect the chassis harness to the Diesel Pro harness.
5. Connect the power lead to the fused accessory side of the ignition switch. The fuse rating depends on the pre-heater installed.

Approved fuse ratings

- 12VDC System:
 - 20 amp fuse for a 155W PTC Pre-heater
 - 25 amp fuse for a 195W PTC Pre-heater
- 24VDC System:
 - 15 amp fuse for a 195W PTC Pre-heater

If the keyed circuit will not handle the required amperage for the pre-heater, use a relay. Prime the Diesel Pro (see page 5) and check for leaks.

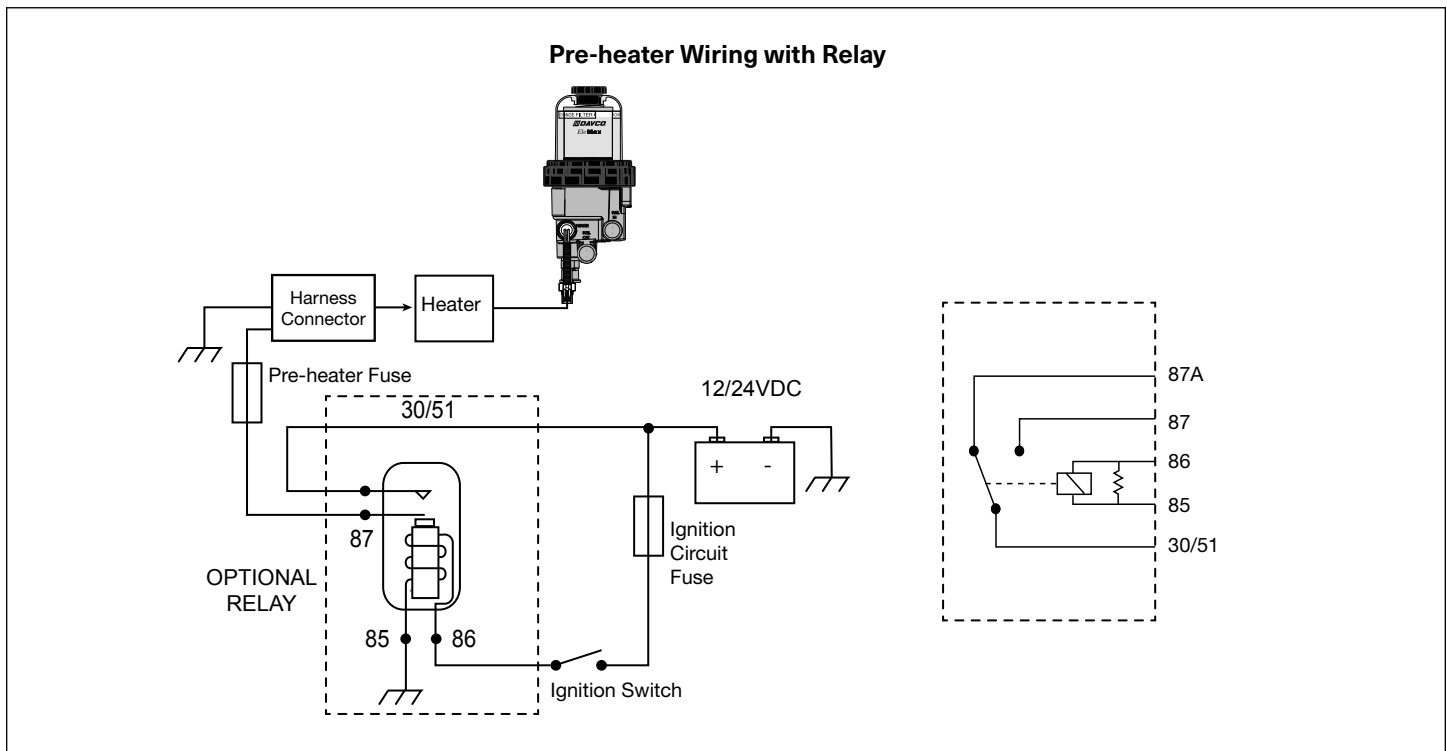

PRIMER PUMP INSTALLATION

1. Remove the vent cap. Place a suitable container under the Diesel Pro.
2. Open the drain valve by turning one to one and a half revolutions and drain the fuel completely from the unit. Close the drain valve.

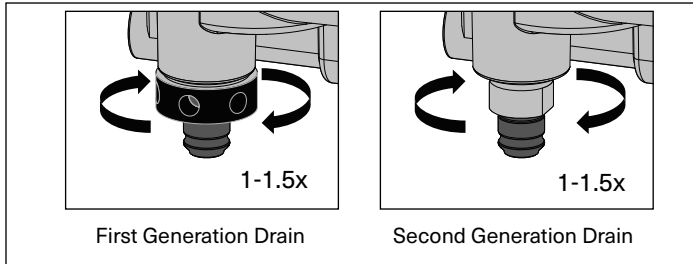

3. Disconnect the fuel inlet hose from the Diesel Pro. Remove the customer interface inlet fitting from the Diesel Pro adapter. Save it for later use.
4. Remove the Diesel Pro adapter inlet fitting.

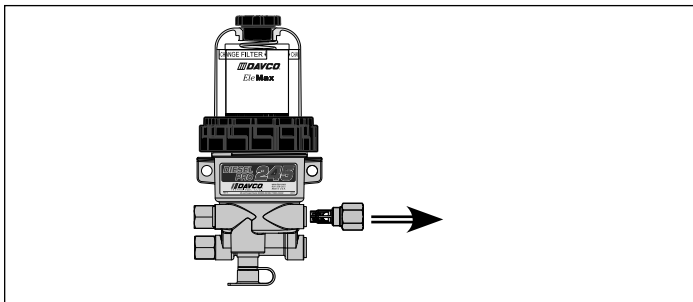

5. Install the primer pump check valve (P/N 103030DAV) into the Diesel Pro body. Torque to 25-40 ft lbs.

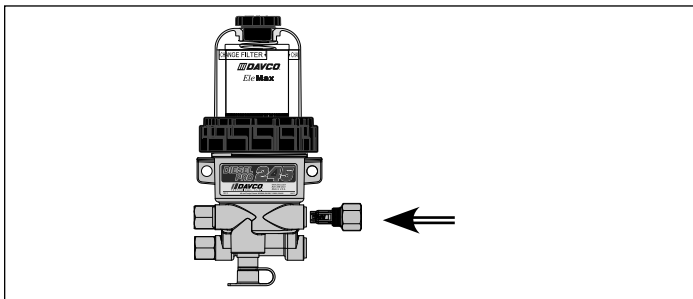

6. Install the primer pump inlet tee into the primer pump check valve and orient as needed. Torque jam nut to 25-40 ft lbs.

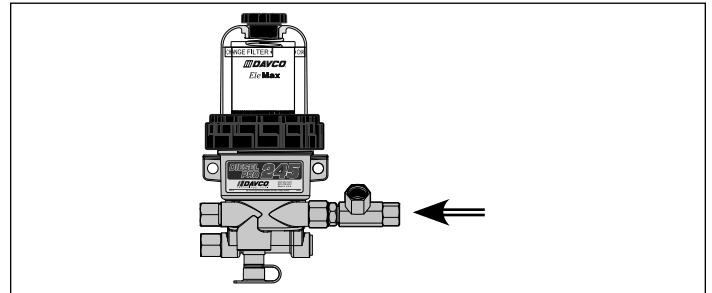

7. Install the primer pump into the inlet tee. Torque to 25-40 ft lbs.

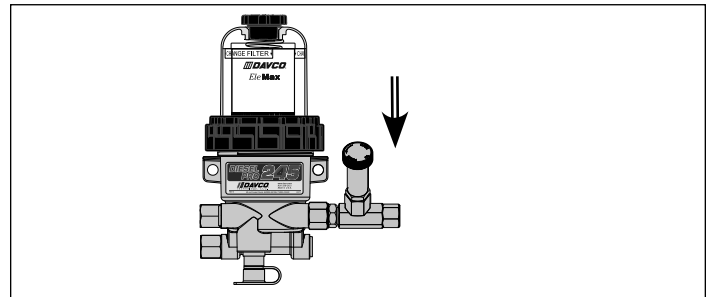

8. Install the customer interface fitting into the fuel inlet. Apply thread sealant to all NPT threads. Torque to OEM specifications.
9. Connect the inlet hose. Torque to OEM specifications.
10. Loosen the plunger knob on the primer pump by turning it counter clockwise.
11. Stroke the primer plunger until the Diesel Pro cover is filled with diesel fuel.

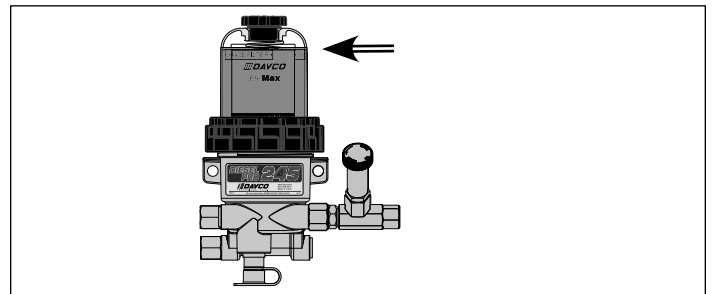

12. Tighten the plunger knob on the primer pump by turning it clockwise.
13. Replace the vent cap and tighten it until it clicks.
14. Start the engine and check for leaks.

VISUAL DIAGNOSTICS - AIR VS. VAPOR BUBBLES

There are two kinds of bubbles that may be visible at the fuel pump inlet of a diesel fuel system. The bubbles can be characterized as either air bubbles or vapor bubbles.

Air Bubbles

Air bubbles are caused by any air leak on the vacuum (suction) side of the fuel system from the fuel tank pick-up to and including the lift pump (see Figure 1).

If there is an air leak in the fuel system, air bubbles will be present in the clear cover of the Diesel Pro. Follow test procedures outlined in "Diagnostic Procedures for Air Leaks" for air leak diagnostics. If there are no bubbles present in the Diesel Pro cover and the engine continues to run rough, lopes or has a loss of power, there may be an air leak between the Diesel Pro outlet port and lift pump inlet. This type of air bubble can be seen if a sight tube is installed at the lift pump inlet. Air bubbles may also be visible in the fuel return (spill) hose out of the fuel gallery. These leaks are easily eliminated by checking and torquing the fuel fittings in the area of the leak.

TEST 1: A quick procedure to determine if the air leak is between the fuel tank and the Diesel Pro is to remove the Diesel Pro inlet hose and route a new hose from the Diesel Pro inlet into a container of fuel or the fuel tank fill cap opening. Start the engine and check for bubbles.

If there are no air leak symptoms, but bubbles are present in a sight tube at the fuel lift pump inlet, they are most likely vapor bubbles.

Vapor Bubbles

All diesel fuel has some level of entrained air caused by the natural splashing that occurs in the fuel tank during normal vehicle or equipment operation. Vapor bubbles develop in the Diesel Pro because the pressure inside the Diesel Pro is lower than the atmospheric pressure in the fuel tank. Vapor bubbles can vary from champagne size up to 1/4" in diameter. They may increase in size or volume as engine RPM increases. The lower pressure draws the entrained air/vapor out of the fuel and these bubbles will be visible as the fuel exits the Diesel Pro (See Figure 2). As the fuel enters the lift pump, it is pressurized and the bubbles are compressed back into the fuel. There will be no bubbles on the fuel return side of the system. These vapor bubbles will not affect the performance of the engine.

TEST 2: An easy way to determine the difference between vapor and air bubbles is by temporarily removing the filter element from the Diesel Pro. Fill the cover with clean diesel fuel, replace the vent cap and re-run the outlet fitting sight glass test. If there are no bubbles visible in the sight glass, then the bubbles that were previously visible were vapor bubbles. If bubbles are still present then they are air. If air bubbles still exist, re-run the test in **TEST 1** to eliminate the chassis plumbing as a variable.

There is no troubleshooting or repair procedure required for vapor bubbles. Vapor bubbles do not cause performance issues and will not be present after the lift pump.

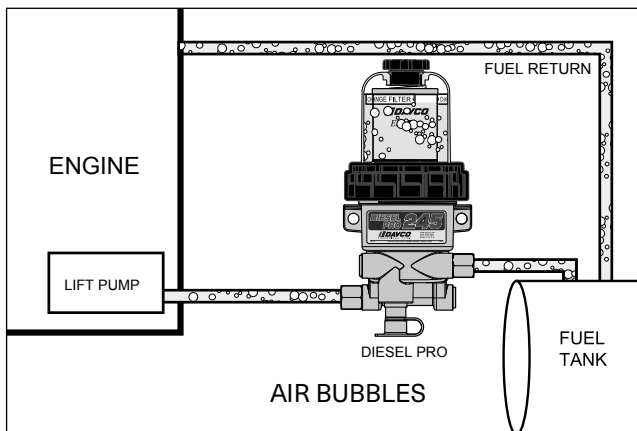

Figure 1

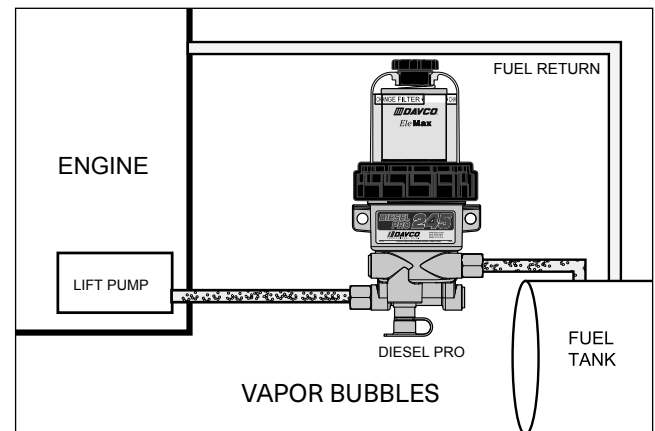

Figure 2

DIAGNOSTIC PROCEDURES - AIR LEAKS







Every Diesel Pro is factory tested for leaks and is identified with a traceable number prior to shipment. Most field issues associated with leaks are related to loose fittings. These leaks are easily eliminated by checking and torquing the fuel fittings in the area of the leak. Some fittings may also require the application of liquid or paste type thread sealant.

All suction side fuel filters experience bubbles. It is normal to see champagne size bubbles in the Diesel Pro cover, at the Diesel Pro outlet or at the lift pump.

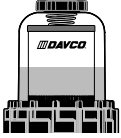
IN ORDER TO RETURN A DIESEL PRO FOR EVALUATION, THE FOLLOWING PROCEDURES/TESTS MUST BE COMPLETED BEFORE REQUESTING A DAVCO RGA (RETURN GOODS AUTHORIZATION) NUMBER.

- I. Air bubbles will be visible in the clear cover of the Diesel Pro if the leak originates between the fuel tank and the Diesel Pro. The following is a quick test to isolate the air leak source.
 - A. Remove the Diesel Pro inlet hose.
 1. Install a jumper hose from the Diesel Pro to the fuel tank (through the fill cap) or to a container of fuel.
 2. Start the engine. If this eliminates the air bubbles, the air source is at the fuel tank fittings or hose connections.
 3. Tighten all fittings and connectors. Retest.
 - a. If air bubbles persist, the air source is on the Diesel Pro side of the system:
 - i. Tighten all fittings on the Diesel Pro.
 - ii. Loosen the collar until it spins freely. Apply downward pressure on the top of the cover and rotate the collar until contact. Use a DAVCO wrench (if necessary) to tighten the collar three additional ribs.
 - b. If the drain valve is suspected, install a plug in place of the drain valve (for test purposes only).
4. If air bubbles persist, test as follows:
 - a. Remove the Diesel Pro from the chassis.
 - b. Plug the fuel outlet port. Do not remove filter, cover/collar, vent cap, drain valve and/or check valve. If the Diesel Pro is equipped with a pre-heater, do not remove the pre-heater.
 - c. Apply 15 PSI of air pressure at the fuel inlet. Immerse the Diesel Pro in a tank of water and look for air bubbles.
 - d. Correct the source of the air leak and retest.
- II. Bubbles Not Visible: If there are symptoms of sucking air (indicated by engine loping/rough running performance/power loss, etc.) and there are no bubbles in the clear cover, the air leak is either at the Diesel Pro outlet fitting, vent cap o-ring, the lift pump inlet connection, or the fuel hose/connections to the lift pump. Inspect and tighten fittings as needed.
- III. Excessive Restriction: If the fuel level is at the top of the filter, replace the fuel filter. The Diesel Pro will not cause excess system restriction if the fuel level is below the top of the filter. The only exception is if the grommet is not installed in the bottom of the filter element.
- IV. Loss of Prime: When air is introduced into the fuel system, (i.e. draining water from the Diesel Pro or when replacing the fuel filter) a check valve is needed to keep the fuel system primed from the Diesel Pro back to the fuel tank. A check valve is standard with every Diesel Pro.
- V. To test for proper check valve operation, put a drain pan under the Diesel Pro, remove the fuel inlet hose and open the vent cap. Fuel should not flow out of the Diesel Pro although slight seepage of fuel is normal. If fuel flows out of the unit, follow the check valve testing procedures. To test for proper check valve operation, place a drain pan under the Diesel Pro, remove the fuel inlet hose and open the vent cap. Fuel should not flow out of the Diesel Pro, although slight seepage of fuel is normal. If fuel flows out of the Diesel Pro fuel inlet, "Check Valve Service" on page 12.

VISUAL DIAGNOSTICS WITH CLEAR COVER

| | |
|--|---|
| <p>Fuel level is not at the top of the fuel filter. → Normal - Do not change the filter.</p> |  |
| <p>Fuel level is at the top of the filter and appears to be full of wax. → Change the filter - Run the engine for a minimum of 25 minutes at idle. Do not run at full RPM.</p> |  |
| <p>Bubbles are seen flowing in with the fuel. → Check all fittings and lines from the fuel tank to the Fuel Processor. Check lower and upper collar o-rings.</p> |  |
| <p>Fuel drains back to the fuel tank when changing the fuel filter or draining separator. → Remove the check valve assembly. Clean or replace and retest. Check air leaks in the fuel system.</p> |  |
| <p>Fuel level is at the top of the filter. Low power. → Change the filter at the first available opportunity.</p> |  |
| <p>There is a power complaint and the fuel level is below the collar. → Check for a missing grommet at the lower end of the filter or missing/broken spring at top of filter.</p> |  |
| <p>Water is noticed in the cover. → Drain the water.</p> |  |

DIAGNOSTIC PROCEDURES - CHECK VALVE AND PRE-HEATER TESTING

Check Valve Service

To test for proper check valve operation, remove the fuel inlet hose and open the vent cap. Fuel should not flow out of the Diesel Pro, although a slight seepage of fuel is normal. If fuel drains back to the fuel tank, remove the check valve assembly at the fuel inlet fitting. Refer to the table on the Service Parts page for ordering information.

1. Use a back-up wrench to hold the check valve body and remove the fuel hose from the inlet of the Diesel Pro.
2. Remove and disassemble the check valve assembly.
3. Clean and inspect the check valve body. Replace the check valve body if any cuts, grooves or nicks are evident or if the ball seat is not smooth.
4. Inspect the check valve spring and spring retainer. If the spring or spring retainer is broken or if the check ball has groves, nicks or is out of round, replace with a check valve service kit. Otherwise, clean and reassemble the check valve assembly.
5. The spring retainer snaps into a groove in the check-valve body.
6. Replace the check valve assembly into the body and torque to 25-40 ft-lbs.
7. Connect the fuel inlet hose, using liquid or paste type thread sealant.
8. Prime the fuel system, start the engine and check for any fuel leaks.

**PTC Pre-heater/Overnight Heater
Testing Procedures**

⚠ Do not energize pre-heater/heater outside of the Diesel Pro. Caution! Very hot.

Equipment Needed: A precision low resistance ohm meter capable of measuring with accuracy to two decimal places.

1. Disconnect the harness from the pre-heater or overnight heater.
2. Connect the ohm meter leads to the pins of the pre-heater or overnight heater. Use the following to determine whether the resistance value is in the acceptable range.

| PRE-HEATER | WATTS | RESISTANCE RANGE (OHMS) |
|-------------|-------|---------------------------|
| 12VDC (PTC) | 195 W | 0.4 to 0.6 @ 77°F (25°C) |
| 24VDC (PTC) | 195 W | 2.0-3.0 @ 77°F (25°C) |
| 12VDC (PTC) | 155W | 0.95 to 1.2 @ 77°F (25°C) |

| OVERNIGHT HEATER | WATTS | RESISTANCE RANGE (OHMS) |
|------------------|-------|--------------------------|
| 120VAC | 75 W | 173 to 203 @ 77°F (25°C) |

FILTER CHANGE PROCEDURE

1. Turn off the engine. Remove the vent cap and dispose of the o-ring. Clean the threads of the vent cap and on the top of the cover. Set the vent cap aside.
2. Open the drain valve by turning 1½ turns. Allow the unit to drain completely. First generation: Close drain without tools. Second Generation: Hand turn until contact, then tighten an additional quarter turn.

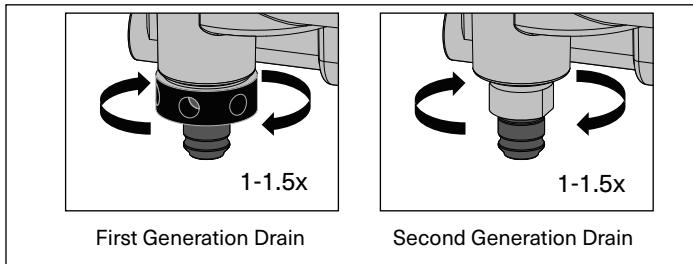

3. Using the Collar Wrench, loosen the collar. Remove the clear cover and collar from the Diesel Pro. Discard the cover o-ring and install a new o-ring (supplied with the filter) on the cover. Clean the threads on the collar and the body of the Diesel Pro.
4. Install the new o-ring on vent cap (supplied with the filter).
5. Remove the filter element from the Diesel Pro by pulling upward.
6. Install the new filter element. Position the filter element so the key is lined up with the keyway on the separator plate of the housing. Use the arrow on the top of the endplate to align the filter. Ensure the filter element is fully seated by firmly pushing on the endplate. The filter should not rotate freely.

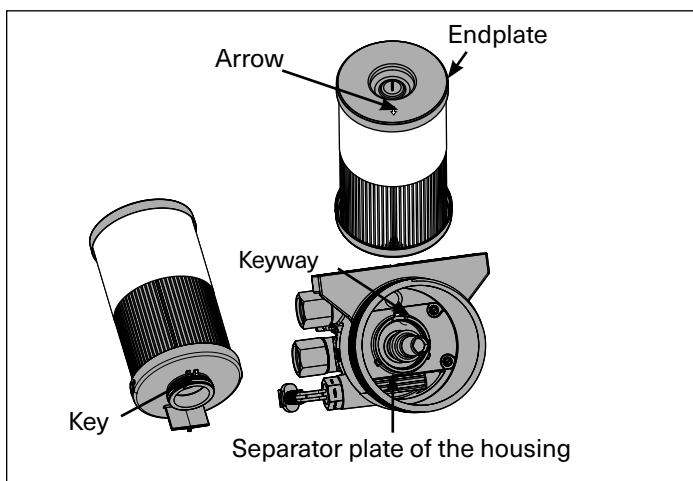

7. After checking to make sure the new o-ring seal is seated correctly on the base of the cover, install the cover and collar.
8. Re-install the clear cover and collar. Apply downward pressure on the top of the cover and rotate the collar until contact.
9. Use a DAVCO wrench if necessary to tighten 3 additional ribs.

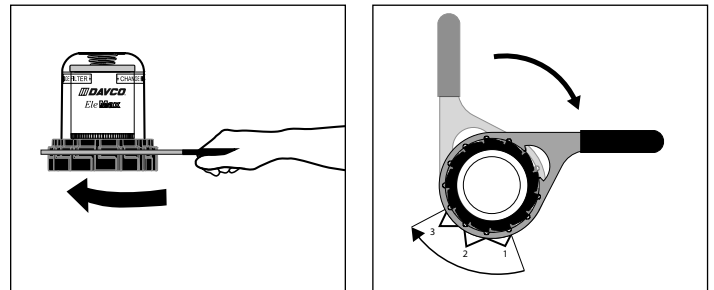

10. Prime the unit by filling the clear cover with clean diesel fuel until it reaches the top of the filter.
11. Install the vent cap. Tighten the vent cap by hand until it clicks.

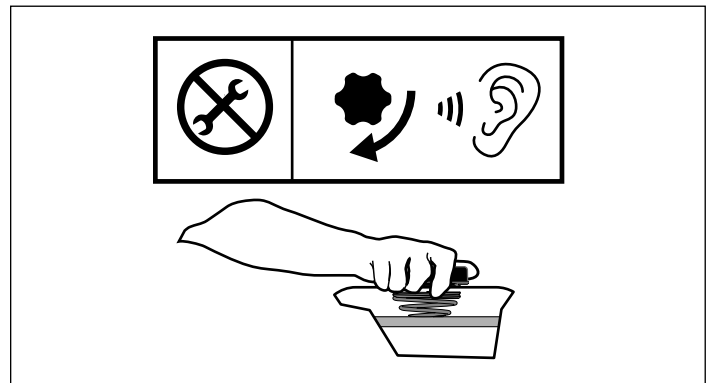

12. Start the engine and run for one minute. **Slowly** open the vent cap and allow the fuel to drop to about one inch above the collar.
13. Tighten the vent cap by hand until it clicks. Check for leaks.

PREVENTATIVE MAINTENANCE

Preventative Maintenance

Environmental Concerns and Seasonal Maintenance

- Steam clean the Diesel Pro with fresh water regularly to keep corrosive salt or dirt from building up on the housing, cover and collar.
- Extreme winter or salt corrosion environments may require lubrication of the collar with anti-seize lubricant every 180 days.

Weekly water drains

1. Turn off the engine and remove the vent cap.
2. Place a suitable container under the Diesel Pro and open the drain valve.
3. Collected water will flow into the container. When fuel begins to flow out the drain, close the drain valve. Drain the least amount of fuel as possible.
4. Install the vent cap and tighten it by hand until it clicks.
5. Start the engine and raise the RPM for one minute to purge the air from the system.

During each filter change

- Change the o-rings on the cover and vent cap (included with the service filter kit).

Annual inspection

- Inspect all electrical connections for corrosion.
- Inspect all fuel fittings for leaks.
- Inspect the Diesel Pro for damage or signs of leaks.

SERVICE PART NUMBERS

| SERVICE PARTS AND KITS | | |
|--|------------|--|
| A | 240023DAV | Vent Cap Service Kit (vent cap and o-ring) |
| B | 243013SDAV | Cover Service Kit (Collar, Spring, Vent Cap and Vent Cap O-ring - Collar o-ring not included) |
| C | 243017DAV | Cover with Red Stripe and Black Band (Collar, Spring, Vent Cap and Vent Cap O-ring - Collar o-ring not included) |
| D | 380056DAV | Filter Spring |
| E | 240002SDAV | Collar |
| F | 232009DAV | O-Ring Service Kit (Vent Cap/Cover) |
| G | 245013DAV | Check Valve Service Kit (Ball, Spring, and Retainer) |
| | | |
| H | 245010DAV | Check Valve Assembly for DTNA Includes Body (7/8"-14 to M22) and Check Valve Service Kit |
| | 245014DAV | Check Valve Assembly Includes Body (3/8"-18) and Check Valve Service Kit |
| | | |
| I | 245011DAV | Adapter 7/8"-14 to M22 |
| J | 102821SDAV | Plug 7/8"-14 |
| K | 485022DAV | Quick Connect Drain Valve - Includes: valve body, retaining ring (L), both seals (M), drain valve and protective cap (N) |
| L | 485025DAV | Retaining Ring |
| M | 485021DAV | Drain Valve Seal Service Kit |
| N | 102712DAV | Drain Valve Dust Cap |
| O | 390456DAV | WIF Port Plug 1/2"-20 |
| <p>Pre-heater, Overnight Heater, Priming Pump and Water in Fuel Sensor (WIF) information is on the following pages.</p> | | |

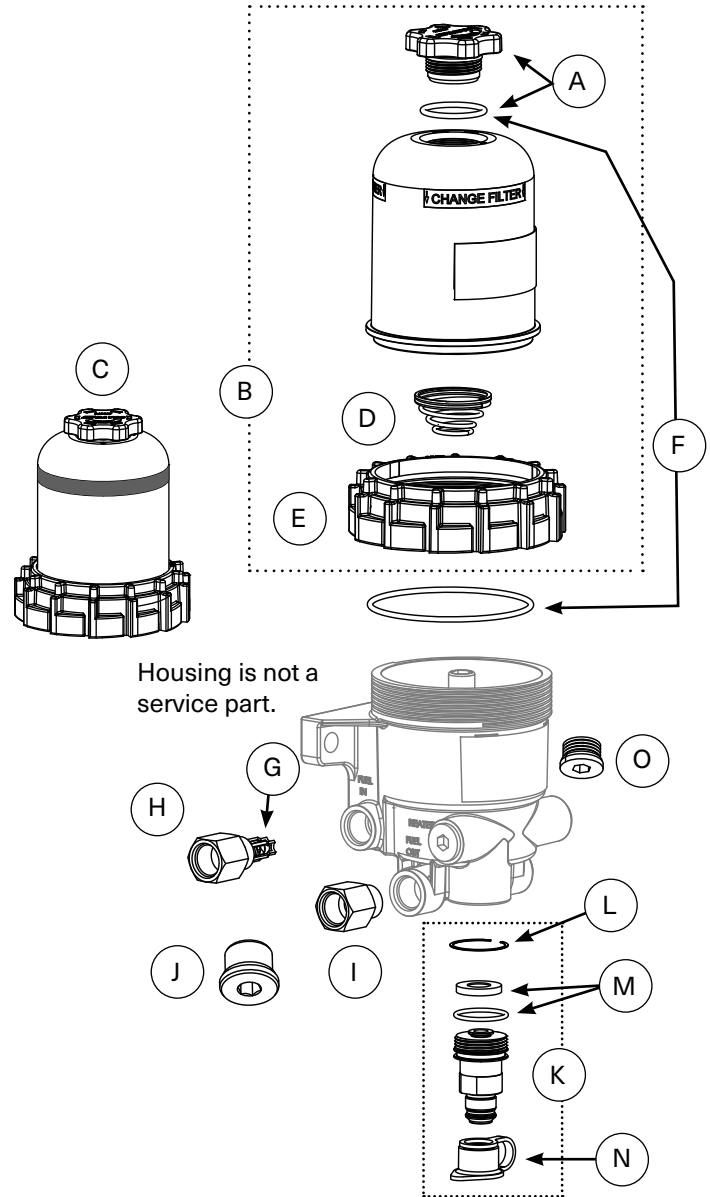

| METAL | COMPOSITE | HEAVY DUTY |
|-----------|-----------|------------|
| 232007DAV | 232002DAV | 243030DAV |
| | | |

| Filters are available through OEM Distributors | |
|--|-------------|
| DDC | A0000904851 |
| Fleetguard | FS20081 |

SERVICE PART NUMBERS

| PRE-HEATER PARTS | | |
|------------------------|--|--|
| 103525DAV | 12VDC 195W PTC Pre-heater, Weather Pack Connector, 7/8"-14 UNF Threads, Harness Length 7.50" | |
| 103526DAV | 12VDC 195W PTC Pre-heater, Metri-Pack Connector, 7/8"-14 UNF Threads, Harness Length 7.50" | |
| 103540DAV | 24VDC 195W PTC Pre-heater, Weather Pack Connector, 7/8"-14 UNF Threads, Harness Length 7.50" | |
| 103552DAV | 12VDC 195W PTC Pre-heater, Metri-Pack Connector, 7/8"-14 UNF Threads, Harness Length 7.50" | |
| 103595DAV | 12VDC 155W PTC Pre-heater, Metri-Pack Connector, 7/8"-14 UNF Threads, Harness Length 7.50" (Freightliner Only) | |
| 102220DAV | Pre-heater Chassis Harness, Weather Pack Connector, Wire Lengths 24" and 180" | |
| 102376DAV | Pre-heater Chassis Harness, Metri-Pack Connector, Wire Lengths 24" and 180" | |
| OVERNIGHT HEATER PARTS | | |
| 102145DAV | 120VAC 75W Overnight heater | |
| 101868DAV | 120VAC Overnight Heater Straight Cord, Cord length: 72" | |
| 102015DAV | 120VAC Overnight Heater "Y" Cord, Cord lengths: 84" and 120" | |

SERVICE PART NUMBERS

| WATER-IN-FUEL (WIF) SENSOR PARTS | | |
|----------------------------------|---|--|
| 102512DAV | Two Pin WIF, Deutsch Connector (gray), ½"-20 UNF Threads, Harness Length 3.36" | |
| 102521DAV | Two Pin WIF, Deutsch Connector (black), ½"-20 UNF Threads, Harness Length 3.36" | |
| 102697DAV | Two Pin WIF, Metri-Pack Connector, ½"-20 UNF Threads, Harness Length 17.5" | |
| 102770DAV | Two Pin WIF, Metri-Pack Connector, ½"-20 UNF Threads, Harness Length 6.50" (Freightliner) | |
| 103111DAV | Two Pin WIF, Tyco/AMP Connector, ½"-20 UNF Threads, Harness Length 3.25" (Paccar) | |
| 102600DAV | Two Pin WIF Wiring Harness (Used with 102512DAV and 102521DAV) Deutsch Connector Wire Lengths 12" and 72" | |
| PRIMER PUMP PARTS | | |
| 103030DAV | Check Valve for Primer pump, 7/8"-14" | |
| 103036DAV | Kit, Primer pump ½"-14, Includes Plunger, Tee Fitting, Check Valve and Instructions | |
| 103292DAV | Kit, Primer pump 3/8"-18, Includes Plunger, Tee Fitting, Check Valve and Instructions | |

WARRANTY POLICY

Please review DAVCO's Product Warranty terms and conditions carefully before installing and/or using a DAVCO product.

Diesel Pro® 243, Diesel Pro® 245, Fuel Pro® 382, Fuel Pro® 482, Fuel Pro® 483, Fuel Pro® 485, Fuel Pro® 487, Fuel Pro® 488, Industrial Pro®, Pro-Chek®, Sea Pro®

DAVCO Technology, LLC warrants these products to be free of defects in material and workmanship for five years, 500,000 miles or 10,000 hours (whichever comes first) and electrical parts for two-years, 200,000 miles or 4,000 hours (whichever comes first) from the purchase date*.

Shop Pro®

DAVCO Technology, LLC warrants the Shop Pro (except for the motor) to be free of defects in material and workmanship for two years from the date of purchase. The Shop Pro motor is warranted for one year from date of purchase.

REN Products, EyeMax®, and Fuel Pro® 384

DAVCO Technology, LLC warrants these products to be free of defects in material and workmanship for two-years or 200,000 miles (whichever comes first) from the purchase date.

By installing and/or using the product, you agree to be bound by the following:

This Warranty does not apply to:

- Failure or inadequate performance due to improper installation, misuse, misapplication, faulty installation, alteration/modification, poor maintenance, neglect, accident, or conditions resulting from actions outside DAVCO's control, including but not limited to the use of contaminated, corrosive, and unapproved fluids.
- Downtime, loss of use, loss of profits or income, loss of capital, cost of substitute equipment, living expenses, claims by purchaser's customers or other third parties, or other incidental, special or consequential damages.
- Attachments, accessory items, and parts not manufactured or distributed by DAVCO.
- Any aftermarket or OEM component not approved specifically to work with a DAVCO manufactured product
- Product that has been installed with aftermarket parts or altered or modified in any way.
- Normal wear and tear, abuse, vandalism, acts of God, improper storage or handling, disasters such as flood, fire, or war, failure to operate, maintain or repair in accordance with instructions, or failure to repair the vehicle into which the product is installed in accordance with the vehicle manufacturer's instructions or common maintenance practices.

This warranty is the sole warranty made by DAVCO. DAVCO makes no other warranties, expressed or implied, of merchantability or fitness for a particular purpose.

In the unlikely event of a defective product, DAVCO will either rework the defective product or replace it at DAVCO's discretion. If you feel you have a warrantable issue, contact DAVCO at 800-328-2611 for a Return Goods Authorization (RGA) number **. An RGA number is required prior to the return of any product.

* Purchase Date: The date of the first retail purchase of a new vehicle or piece of equipment from the OEM dealer or factory. For "Over the Counter" purchase: The date of sale to the first retail customer.

**Products submitted for Warranty consideration will be inspected by DAVCO personnel. Re-work or replacement will be based on DAVCO's Warranty procedure and/or the results of their evaluation. DAVCO's Warranty Program does not in any way constitute a product guarantee.



A Clarience Technologies Company

PARTS RETURN POLICY

Parts Return General Policy

A Return Goods Authorization (RGA) must be obtained from DAVCO prior to returning any products. Returns may be accepted under the following circumstances:

Order Shipping Error: A credit against the original invoice, including freight charges for both ways will be issued for returns in which DAVCO inadvertently shipped incorrect quantity or product.

Overstock: Returns for ordering more product(s) than required, or incorrect part(s), will be accepted within 60 days from the date of purchase. Proof of purchase will be required, i.e.: original invoice/delivery receipt. These types of return(s) are subject to a minimum restock fee of 40% or \$40.00, whichever is higher. Additional restock fees may apply. Product(s) will be inspected for "like new" condition and additional costs will be the responsibility of the customer. No obsolete parts may be returned.

Freight charges for return(s) will be the responsibility of the customer.

