

# FUEL PRO<sup>®</sup> 385

## PRODUCT DATA SHEET

**DAVCO FUEL PRO 385** provides filtration and fuel water separation for diesel engines with flow rates up to 180 gallons per hour.

The Fuel Pro 385 is designed specifically for Daimler Trucks, with an optional pre-heater, overnight heater and water-in-fuel sensor.

Three layer filter design, with filtration to 10 microns, provides enhanced water separation capabilities for ultra-low sulfur diesel fuel with low interfacial tension.

### Applications

- Daimler Trucks with flow rates up to 180 gph

### Models and Options

- Base Model — Unheated
- 12VDC — uses ignition switch to heat fuel prior to running the engine
- 120VAC Overnight heater — prevents gelling while parked overnight
- Water-In-Fuel (WIF) sensor

### Typical Installation

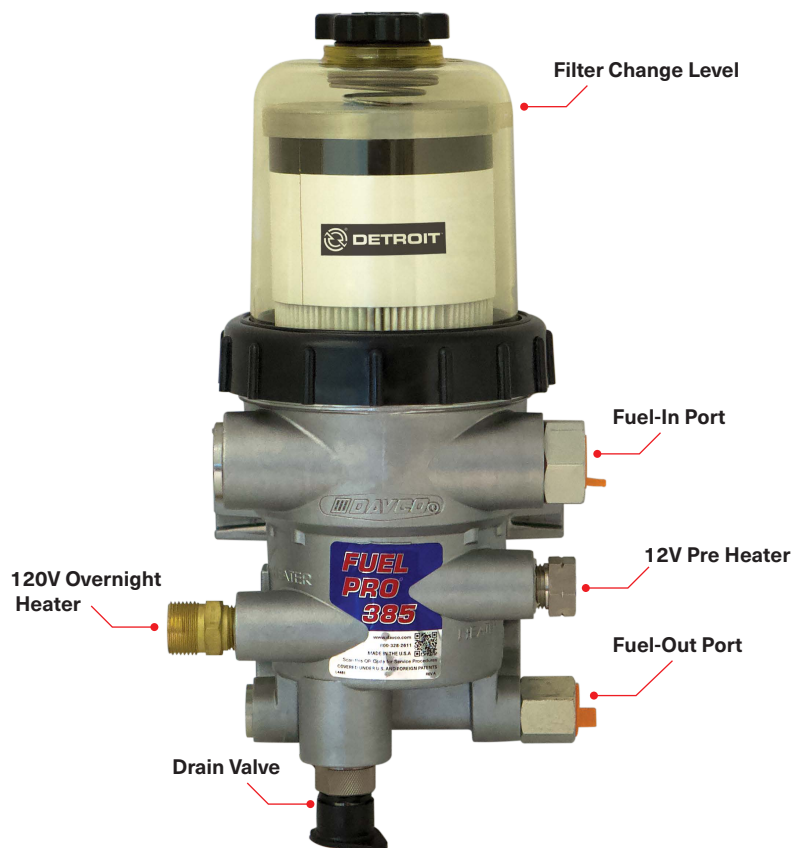
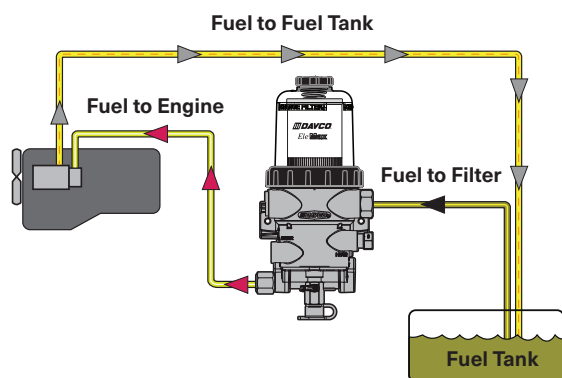

### Filter Technology

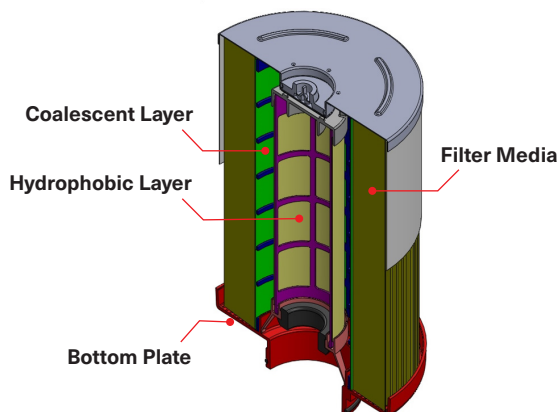

A Clariance Technologies Company

DAVCO Technology, LLC

1600 Woodland Drive, Saline, MI 48176-1629

800-328-2611

customerservice@davco.com

www.davco.com

# FUEL PRO® 385

## Specifications

Height, Overall	15.39 (390.8 mm)
Depth, Overall	6.58 inches (167.1 mm)
Width, Maximum	7.19 inches (182.63 mm)
Weight, Dry	Approx. 8-12 lbs
Minimum Service Height	3.5 inches (38.1mm)
Max Fuel Flow	180 gph
Pre-heater	12VDC, 155W or 195W
Overnight heater	120VAC, 75W

## Filtration Performance (10 micron at 174 GPH)

Emulsified Water Removal	SAE J1488 is 96.9%
Dirt Holding Capacity	89 grams

## Port Interface

Fuel In	M22x 1.5-6H
Fuel Out	M22x 1.5-6H

## Dimensions

Dimensions are in inches [millimeters]

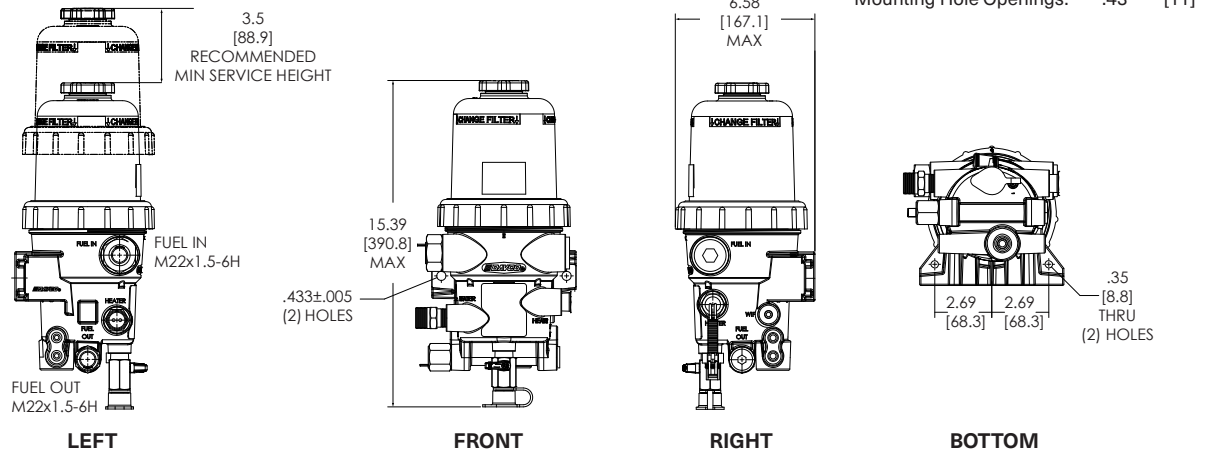

## Part Numbers

DAVCO PART NUMBER	DTNA PART NUMBER	FUEL IN/FUEL OUT	OPTIONS
385150LLFTL-10	03-44726-000	Left/Left	Unheated
385150RRFTL-10	03-44726-006	Right/Right	Unheated
385152LLFTL-10	03-44726-001	Left/Left	12V Pre-Heater
385152RRFTL-10	03-44276-007	Right/Right	12V Pre-Heater
385162LLFTL-10	03-44726-002	Left/Left	12V Pre-Heater and 120V Overnight Heater
385162RRFTL-10	03-44726-008	Right/Right	12V Pre-Heater and 120V Overnight Heater
386151LLFTL-10	03-44726-003	Left/Left	Water in Fuel Sensor
386151RRFTL-10	03-44726-009	Right/Right	Water in Fuel Sensor
386153LLFTL-10	03-44726-004	Left/Left	12V Pre-Heater and Water in Fuel Sensor
386153RRFTL-10	03-44726-010	Right/Right	12V Pre-Heater and Water in Fuel Sensor
386163LLFTL-10	03-44726-005	Left/Left	12V Pre-Heater, 120V Overnight Heater, Water in Fuel Sensor
386163RRFTL-10	03-44726-011	Right/Right	12V Pre-Heater, 120V Overnight Heater, Water in Fuel Sensor

## DAVCO Technology, LLC

1600 Woodland Drive, Saline, MI 48176-1629  
800-328-2611 www.davco.com customerservice@davco.com

F3513 REV C  
Updated on 07/11/2023