

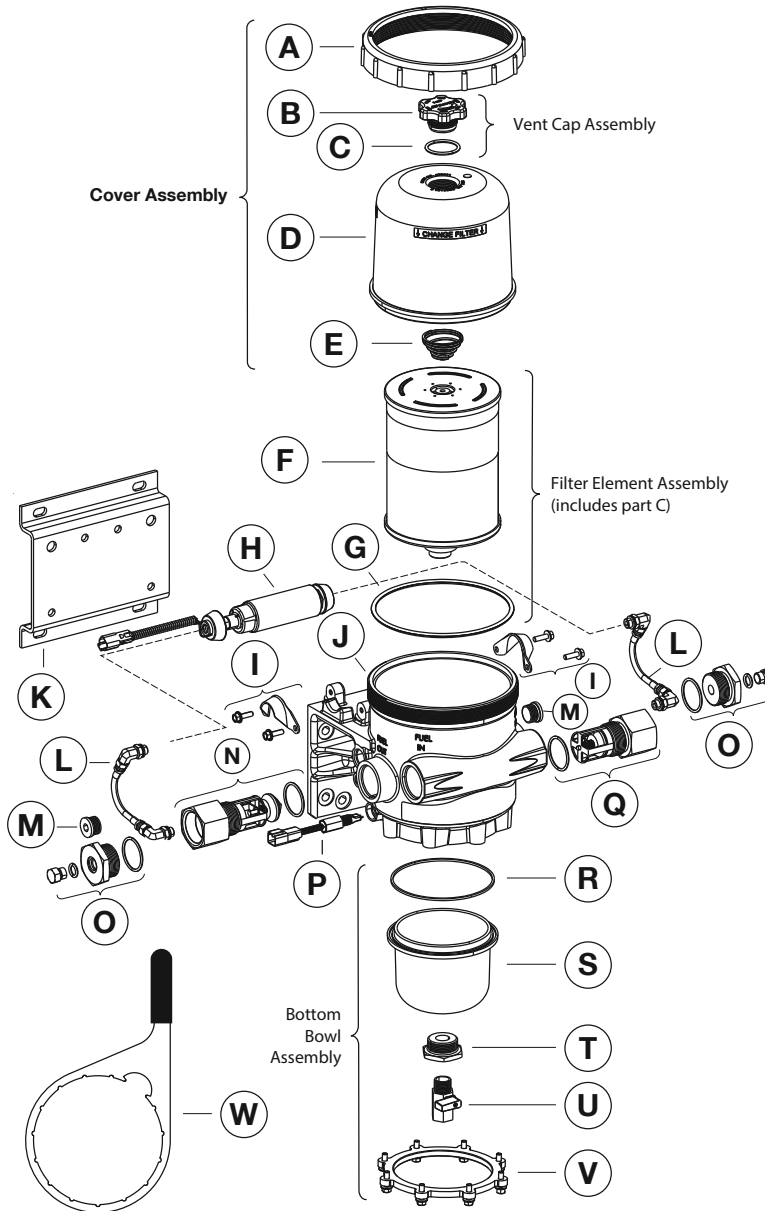

A Clariance Technologies Company

Industrial Pro® Series Filter/ Separator/Warmer Installation Instructions

Industrial Pro® Single Short



Part	Description	Part Number
A	Collar	Cover Assembly SP1127
B	Vent Cap	
C	O-Ring	
	Vent Cap Assembly SP1053	
D	Cover	
E	Filter Spring	
F	Filter Element (includes Part C)	FS53015 (includes Part C)
G	O-Ring	
H	Priming Pump (includes Isolators)	SP1124
I	(2) Priming Pump Clamp and (4) Screws	SP1133
J	Industrial Pro®	See page 14
K	Bracket with Fasteners	SP1131
L	(2) Priming Pump Hoses and (4) Fittings	SP1128
M	Plug 1/2" STOR	SP1125
N	Bypass Check Valve	SP1121
O	Diagnostic Plug Fitting	SP1130
P	Water-In-Fuel (WIF) Sensor	SP1123
Q	Check Valve	SP1120
R	O-Ring	3945125 S
S	Bottom Bowl	Bottom Bowl Assembly (Includes Part R) SP1134
T	Drain Flange	
U	Drain Valve	
V	Bottom Bracket and Bolts (8)	
W	Wrench	SP1076
Not Shown	WIF Wiring Harness	3950729 S
	WIF LED	3946670 S
	Electric Pre-heater	See page 9
	Adapter Fitting, 3/4" to 1-1/4"	SP1135
	Adapter Fitting, 1-1/4" NPT to M42 x 1.5	3956561 S

CAUTION: These instructions are intended for use by professional mechanics who are trained in the proper use of power and hand tools, using appropriate safety precautions (including eye protection).

Industrial Pro® Duplex Short

Part	Description	Part Number
A	Collar	Cover Assembly SP1127
B	Vent Cap	
C	O-Ring	
D	Cover	
E	Filter Spring	
F	Filter Element (includes Part C)	FS53015 (includes Part C)
G	O-Ring	SP1124
H	Priming Pump (includes Isolators)	
I	(2) Priming Pump Clamp and (4) Screws	SP1133
J	Industrial Pro®	See page 14
K	Bracket with Fasteners	SP1429
L	(2) Priming Pump Hoses and (4) Fittings	SP1430
M	Plug 1/2" STOR	SP1125
N	Bypass Check Valve	SP1447
O	Fuel In Diagnostic Plug Fitting	SP1130

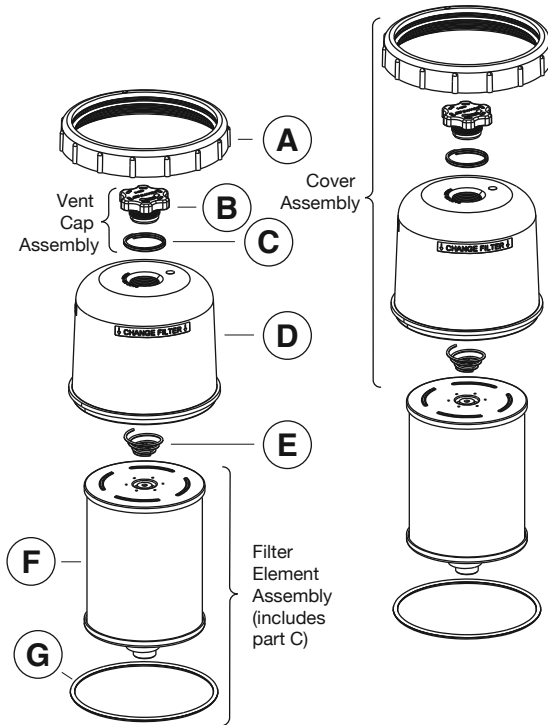

Part	Description	Part Number
P	Fuel Out Diagnostic Plug Fitting	SP1444
Q	Water-In-Fuel (WIF) Sensor	SP72026
R	Check Valve	SP1446
S	Fuel In Fitting (no check valve)	SP1486
T	O-Ring	3945125 S
U	Bottom Bowl	Bottom Bowl and Drain Valve Assembly (Includes Part S)
V	Drain Flange	
W	Drain Valve	SP1134
X	Bottom Bracket and Bolts (8)	
Y	Three-way Valve	SP1431
	Wrench	SP1076
Not Shown	WIF Wiring Harness	3950729 S
	Dual WIF Harness (Duplex only)	SP72028
	WIF LED	3946670 S
	Electric Pre-heater	See page 9
	Adapter Fitting, 3/4" to 1-1/4"	SP1135
	Adapter Fitting, 1-1/4" NPT to M42 x 1.5	3956561 S

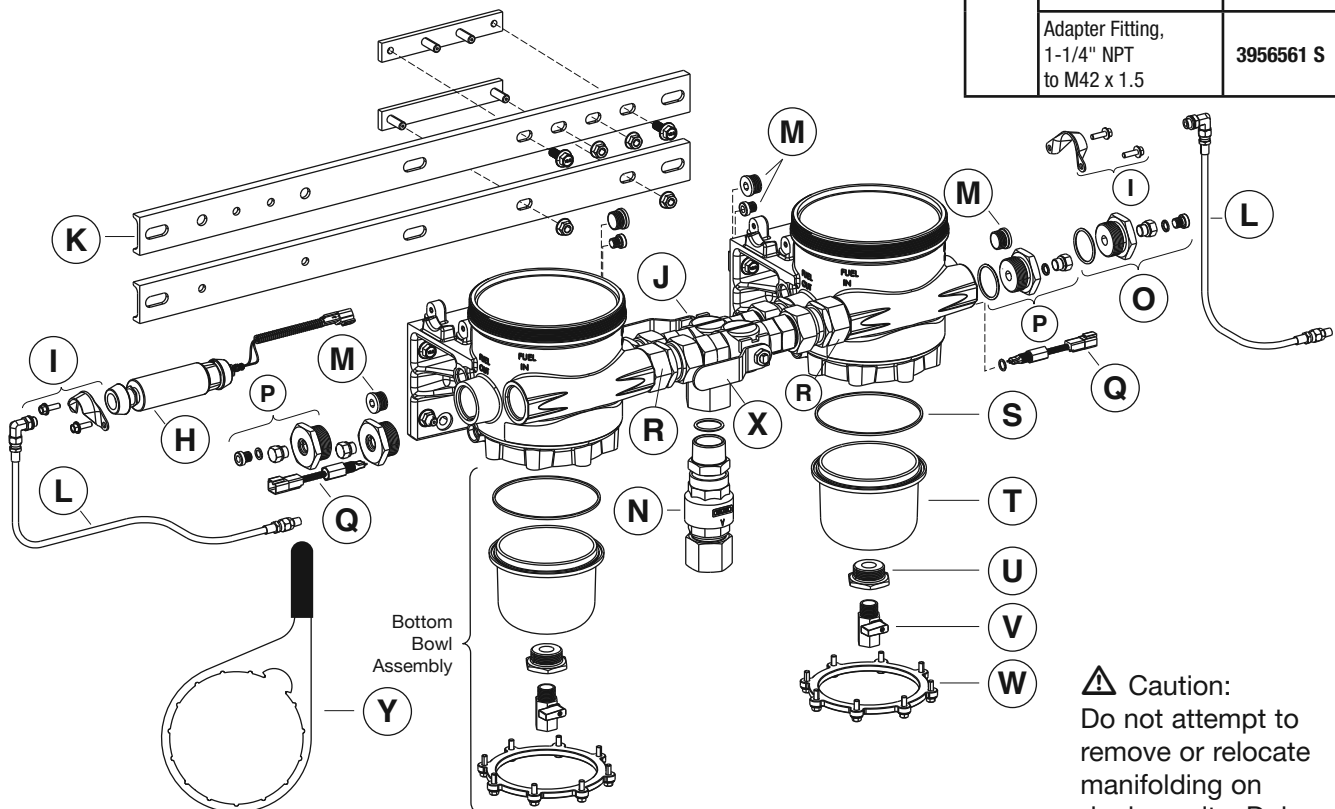

⚠ Caution:
Do not attempt to remove or relocate manifolding on duplex units. Doing so will void the warranty.

Industrial Pro® Single Tall

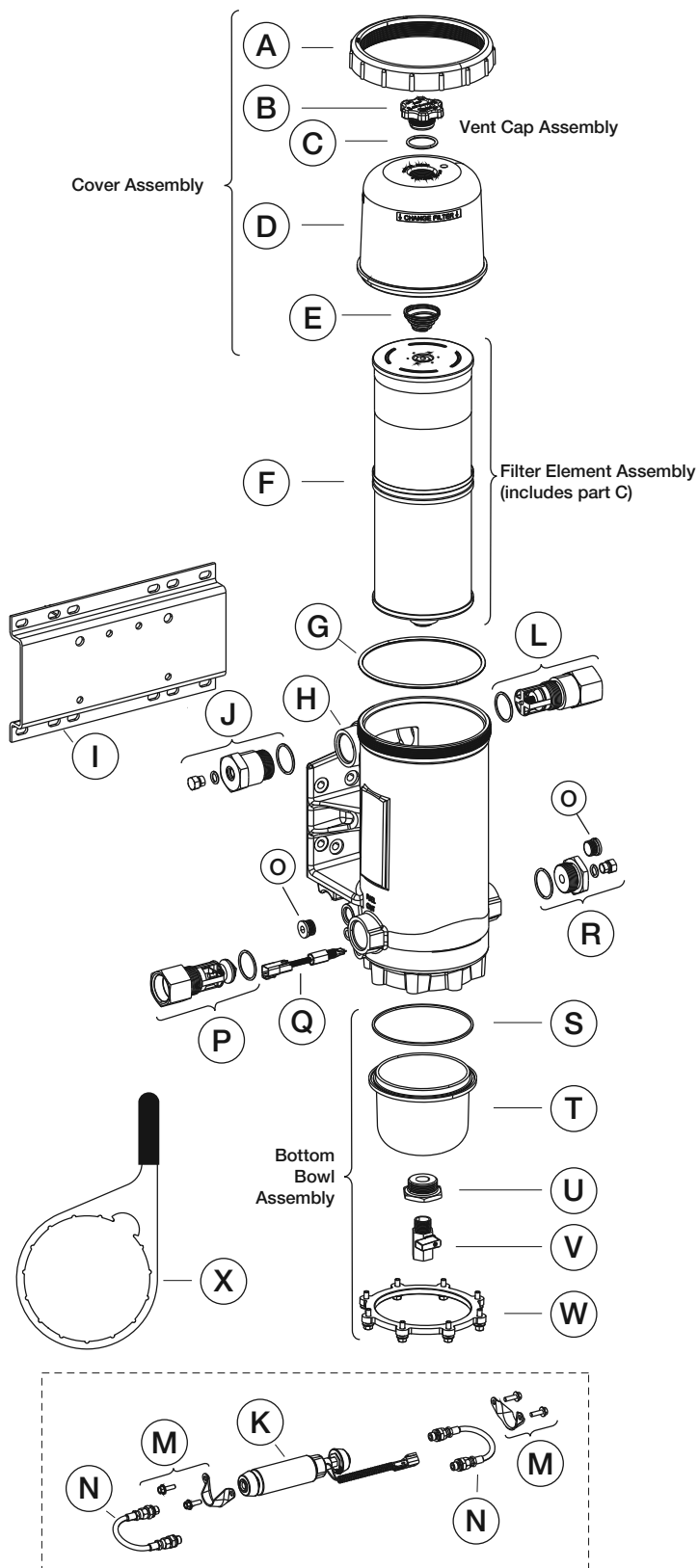

Part	Description	Part Number
A	Collar	Cover Assembly SP1127
B	Vent Cap	
C	O-Ring	
D	Cover	
E	Filter Spring	FS53014 (includes Part C)
F	Filter Element (includes Part C)	
G	O-Ring	See page 14
H	Industrial Pro®	
I	Bracket with Fasteners	SP1132
J	Diagnostic Plug Fitting - Extended	SP1205
K	Priming Pump (includes Isolators)	SP1124
L	Check Valve - Extended	SP1206
M	(2) Priming Pump Clamps and (4) Screws	SP1133
N	(2) Priming Pump Hoses and (4) Fittings	SP1129
O	Plug 1/2" STOR	SP1125
P	Bypass Check Valve	SP1121
Q	Water-In-Fuel (WIF) Sensor	SP1123
R	Diagnostic Plug Fitting	SP1130
S	O-Ring	3945125 S
T	Bottom Bowl	Bottom Bowl and Drain Valve Assembly (Includes Part S) SP1134
U	Drain Flange	
V	Drain Valve	
W	Bottom Bracket and Bolts (8)	SP1134
X	Wrench	SP1076
Not Shown	WIF Wiring Harness	3950729 S
	WIF LED	3946670 S
	Electric Pre-heater	See page 9
	Adapter Fitting, 3/4" to 1-1/4"	SP1135
	Adapter Fitting, 1-1/4" NPT to M42 x 1.5	3956561 S

Industrial Pro® Dual Tall

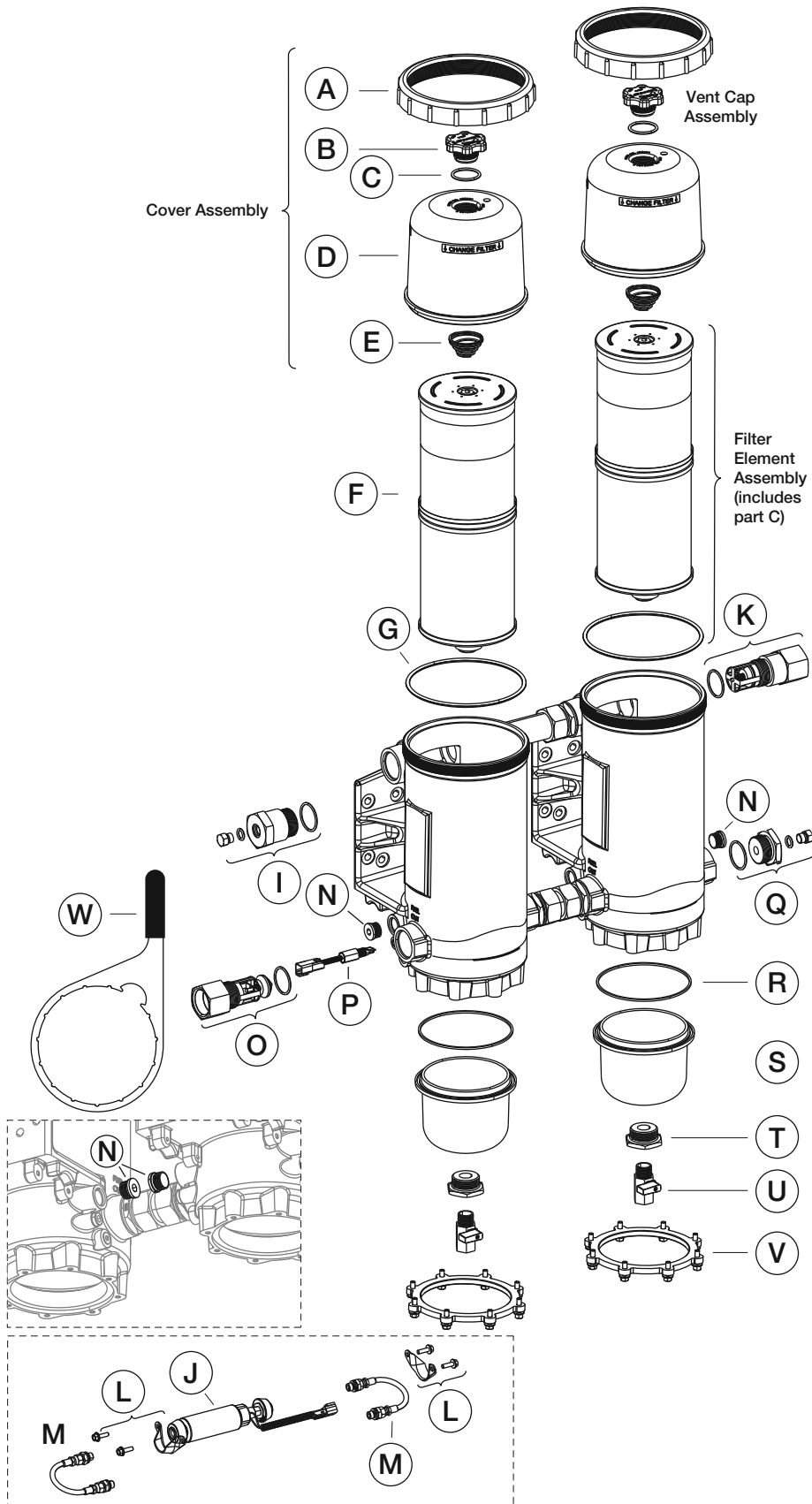

Part	Description	Part Number
A	Collar	Cover Assembly SP1127
B	Vent Cap	
C	O-Ring	
D	Cover	
E	Filter Spring	
F	Filter Element (includes Part C)	FS53014 (includes Part C)
G	O-Ring	See page 14
H	Industrial Pro®	
I	Diagnostic Plug Fitting - Extended	SP1205
J	Priming Pump (includes Isolators)	SP1124
K	Check Valve - Extended	SP1206
L	(2) Priming Pump Clamps and (4) Screws	SP1133
M	(2) Priming Pump Hoses and (4) Fittings	SP1129
N	Plug 1/2" STOR	SP1125
O	Bypass Check Valve	SP1121
P	Water-In-Fuel (WIF) Sensor	SP1123
Q	Diagnostic Plug Fitting	SP1130
R	O-Ring	3945125 S
S	Bottom Bowl	Bottom Bowl Assembly (Includes Part R) SP1134
T	Drain Flange	
U	Drain Valve	
V	Bottom Bracket and Bolts (8)	
W	Wrench	SP1076
Not Shown	WIF Wiring Harness	3950729 S
	WIF LED	3946670 S
	Electric Pre-heater	See page 9
	Adapter Fitting, 3/4" to 1-1/4"	SP1135
	Adapter Fitting, 1-1/4" NPT to M42 x 1.5	3956561 S

Part	Description	Part Number
A	Collar	Cover Assembly SP1127
B	Vent Cap	
C	O-Ring	
D	Cover	
E	Filter Spring	FS53014 (includes Part C)
F	Filter Element (includes Part C)	
G	O-Ring	
H	Industrial Pro®	See page 14
I	Bracket with Fasteners	SP1429
J	Diagnostic Plug Fitting - Extended	SP1205
K	Priming Pump (includes Isolators)	SP1124
L	Check Valve	SP1485
	Fuel In Fitting (no check valve)	SP1516
M	(2) Priming Pump Clamps and (4) Screws	SP1133

Industrial Pro® Duplex Tall

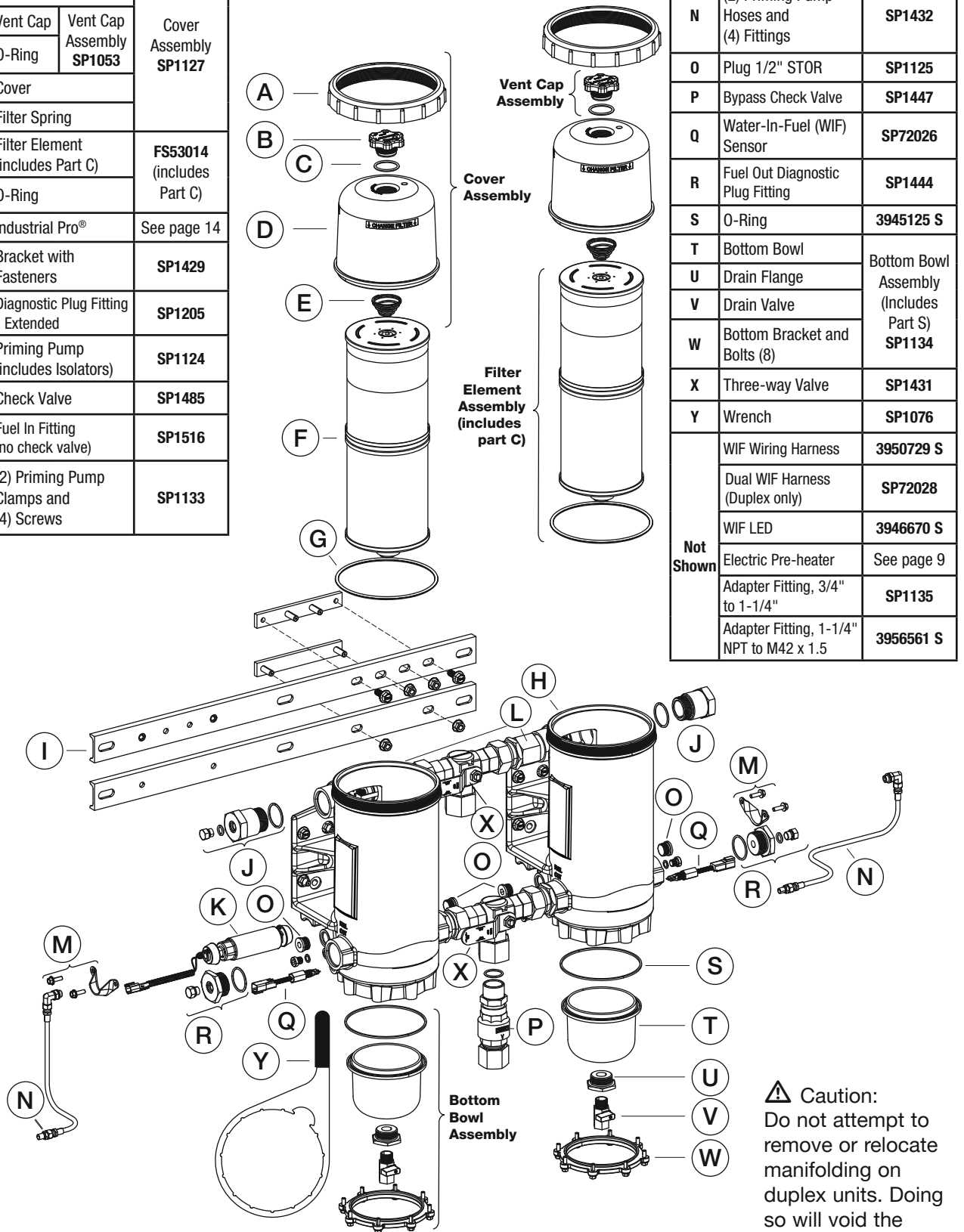

Part	Description	Part Number
N	(2) Priming Pump Hoses and (4) Fittings	SP1432
O	Plug 1/2" STOR	SP1125
P	Bypass Check Valve	SP1447
Q	Water-In-Fuel (WIF) Sensor	SP72026
R	Fuel Out Diagnostic Plug Fitting	SP1444
S	O-Ring	3945125 S
T	Bottom Bowl	Bottom Bowl Assembly (Includes Part S) SP1134
U	Drain Flange	
V	Drain Valve	
W	Bottom Bracket and Bolts (8)	SP1134
X	Three-way Valve	SP1431
Y	Wrench	SP1076
Not Shown	WIF Wiring Harness	3950729 S
	Dual WIF Harness (Duplex only)	SP72028
	WIF LED	3946670 S
	Electric Pre-heater	See page 9
	Adapter Fitting, 3/4" to 1-1/4"	SP1135
Adapter Fitting, 1-1/4" NPT to M42 x 1.5	3956561 S	

⚠ Caution:
Do not attempt to remove or relocate manifolding on duplex units. Doing so will void the warranty.

Part	Description	Part Number
A	Collar	Cover Assembly SP1127
B	Vent Cap	
C	O-Ring	
D	Cover	
E	Filter Spring	
F	Filter Element (includes Part C)	FS53014 (includes Part C)
G	O-Ring	
H	Industrial Pro®	See page 14
I	Diagnostic Plug Fitting - Extended	SP1205
J	Priming Pump (includes Isolators)	SP1124
K	Check Valve - Extended	SP1206
L	(2) Priming Pump Clamps and (4) Screws	SP1133
M	(2) Priming Pump Hoses and (4) Fittings	SP1129
N	Plug 1/2" STOR	SP1125
O	Water-In-Fuel (WIF) Sensor	SP1123
P	Bypass Check Valve	SP1121
Q	O-Ring	3945125 S
R	Bottom Bowl	Bottom Bowl Assembly (Includes Part Q)
S	Drain Flange	
T	Drain Valve	
U	Bottom Bracket and Bolts (8)	SP1134
V	Wrench	SP1076
W	Diagnostic Plug Fitting	SP1130
Not Shown	WIF Wiring Harness	3950729 S
	WIF LED	3946670 S
	Electric Pre-heater	See page 9
	Adapter Fitting, 3/4" to 1-1/4"	SP1135
	Adapter Fitting, 1-1/4" NPT to M42 x 1.5	3956561 S

Industrial Pro® Triple Tall

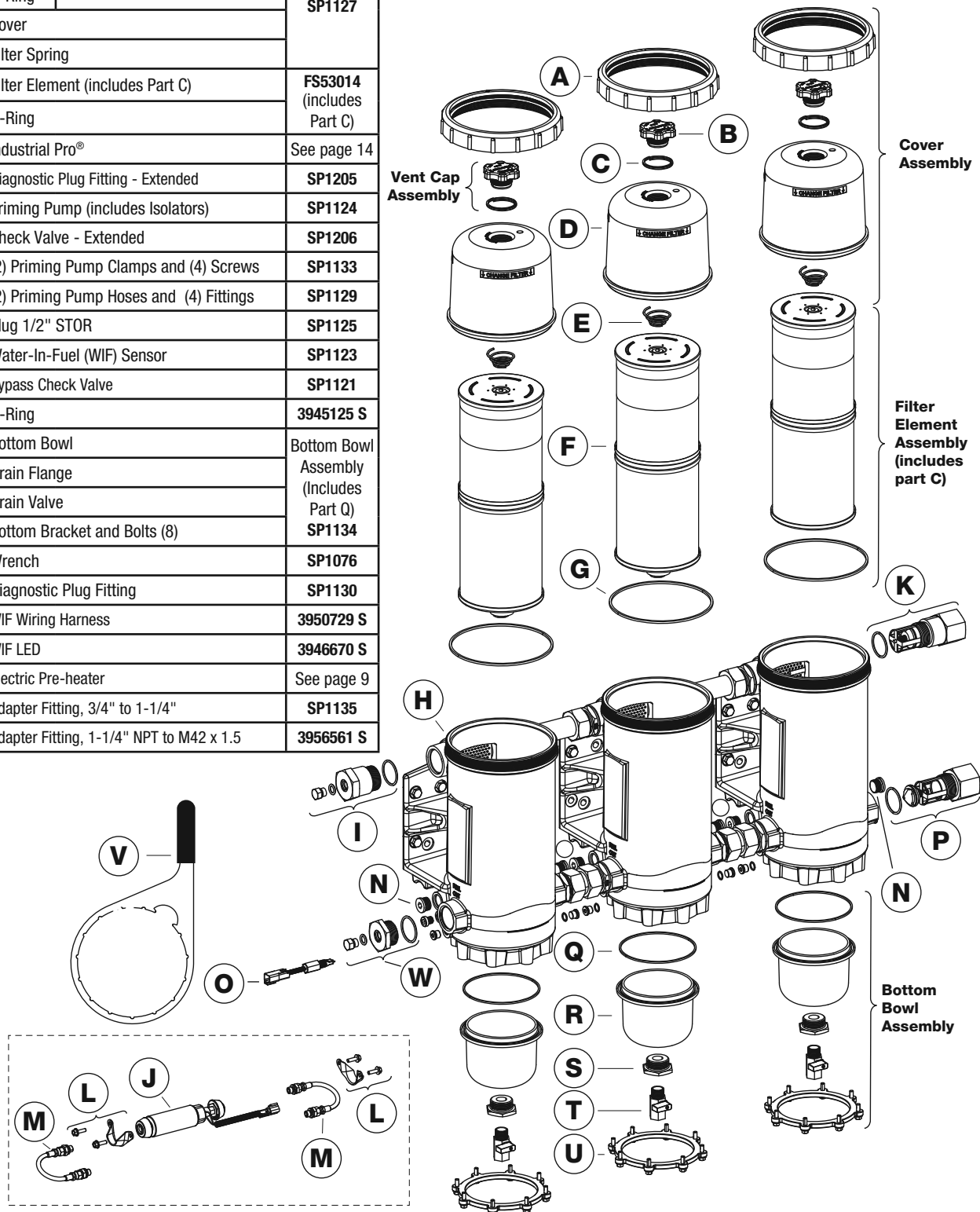

Fuel Processor Installation

This system must be installed between the fuel tank and the transfer fuel pump on the suction side of the fuel system.

- ⚠ **WARNING:** When diesel fuel is circulated through an operating engine, it can become very hot. To prevent personal injury:
- ⚠ **Scalding hazard!** Do not allow heated liquid fuel to come in contact with eyes or unprotected skin.
- ⚠ Heated diesel fuel can form combustible vapor mixtures in the area around the fuel source. To eliminate the potential for fire, keep open flames, sparks or other potential ignition sources away from the work area, and do not smoke during filter replacement or service operations which could result in the escape of diesel fuel or fuel vapors.
- ⚠ **CAUTION:** Always perform engine or vessel fuel system maintenance in a well ventilated area that is kept free of bystanders.
- ⚠ To ensure priming pump hoses are not kinked by mishandling, do not lift or handle the fuel processor by the hoses. Do not allow the weight of the processor to rest on the hoses.

Installation Steps

1. With the engine shut down and at ambient temperature, close the fuel shutoff valve (if equipped) and place a suitable container under the fuel filters.
2. Remove the primary fuel filter element assembly, sedimenter, and/or water separator. Drain the used element and dispose of it in an environmentally responsible manner, according to state and/or federal (EPA) recommendations. The fuel can be returned to the tank. Installation of the Industrial Pro must be on the suction side of the fuel system. Do not exceed 2.2 lb/in² (15 kPa) inlet pressure to the fuel processor.
3. Mount the Industrial Pro[®] in the desired location keeping the following points in mind:

- a. Mounting the Industrial Pro directly on the engine is NOT ALLOWED.
- b. Mount vertically with the cover and element pointing up.
- c. Make sure there is enough top and side clearance for the cover to be conveniently removed for filter replacement.
- d. Filter service clearance:
 - Single Short: 3.5" (89 mm) minimum
 - Duplex Short: 3.5" (89 mm) minimum
 - Single Tall: 6.0" (152 mm) minimum
 - Duplex Tall: 6.0" (152 mm) minimum
 - Dual Tall: 6.0" (152 mm) minimum

⚠ **CAUTION:** The Industrial Pro functions BEST when installed so that the Filter Element is above the "FULL" level of the fuel tank. The housing can be installed up to 6' (1.8 m) below the "FULL" level of the fuel tank. Installing below the "FULL" level causes the starting level to be higher than normal. If mounted below full tank level, a shut off valve will be required at the inlet to allow filter changes without overflow of fuel. Mounting below 6' (1.8 m) eliminates the SEEING IS BELIEVING[®] functionality.

4. Route the fuel supply line from the fuel tank to the Industrial Pro inlet (see Figure 1). Route a fuel line from the Industrial Pro outlet to the fuel pump inlet.

⚠ **CAUTION:** To avoid fuel line water traps that can freeze in cold conditions and restrict, or block, the flow of fuel to the engine, be certain that there are no low spots in the hoses when routing them in the engine compartment.

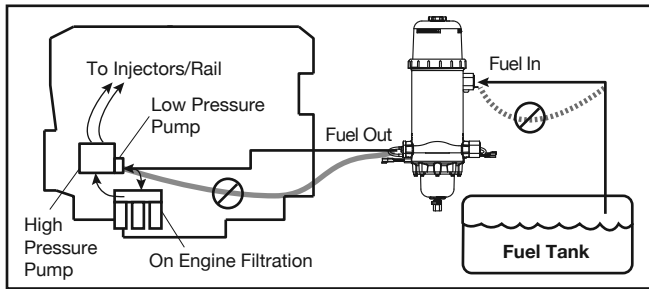

Figure 1 - Industrial Pro Connections

Note: When the engine is shut off, fuel levels may drop until the engine is restarted.

5. To minimize restriction, observe the following guidelines when plumbing the system.
 - a. Keep the fuel line routing as smooth as possible with no low hanging loops which can trap water.
 - b. Use 90° elbows only when necessary.
 - c. If the fuel hoses are made to length on the job, be sure that the inner liner of the fuel hose is not cut by the fitting, creating potential check valve effects. Ensure hoses are clean and free of debris before installing.

⚠ CAUTION: To avoid damaging the aluminum fuel housing, do not overtighten fuel lines or line fittings. Do not exceed 65 ft-lbs (88 N-m). See the table of torque values on page 13.

6. Apply liquid thread sealant to the inlet and outlet hose threads and connect the hoses to the unit.

Installing a WIF (Water In Fuel) Sensor With Optional Indicator (LED)

Note: Drain the unit before installing or servicing any components on the unit.

1. Install the WIF Probe (SP1123 for all models except for the Industrial Pro Duplex Short and industrial Pro Duplex Tall; for the Industrial Pro Duplex Short and Industrial Pro Duplex Tall, use SP72026) into the side of the Industrial Pro® (see Figure 2). Torque to 20-24 in-lbs (2.3-2.7 N-m).

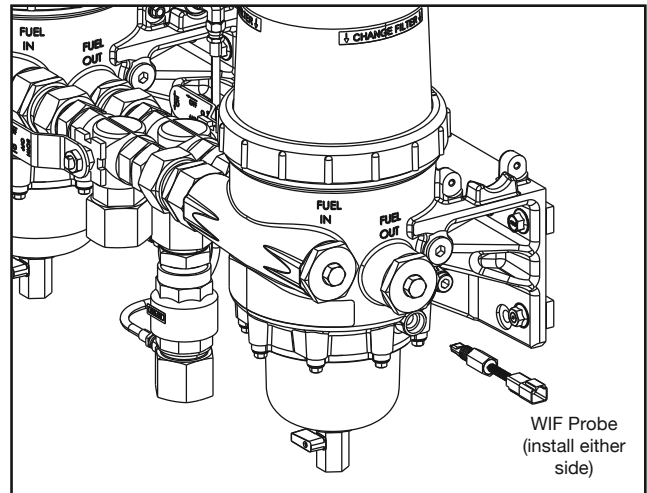

Figure 2 - WIF Probe Installation

2. Install the WIF wiring harness (3950729 S) on the WIF Probe. The harness has the following connections: 12" (304.8 mm) black ground lead with a 3/8" (9.53 mm) diameter loop end and a 72" (1828.80 mm) green WIF wire.

Note: For the Industrial Pro Duplex Short and Industrial Pro Duplex Tall configurations, a Dual WIF wiring harness (SP72028) is included to run both sensors in parallel. To ensure proper readings, the Y harness must be installed.

3. Drill 1/2" (12.70 mm) hole in the control panel where the WIF LED (3946670 S) is to be located.
 - a. Installation must have 1.5" (38.10 mm) of clearance behind dash or control panel.
 - b. Use caution not to damage nearby components when drilling.
4. Install WIF LED by pressing firmly into the drilled hole.
5. Connect the 4" (101.60 mm) black ground wire on WIF LED to a ground source. Attach additional black wire as needed.
6. Connect the 12" (304.8 mm) black ground lead with a 3/8" (9.53 mm) diameter loop end on the WIF wiring harness to ground source near Fuel Processor (if applicable).
7. Connect 72" (1828.80 mm) green signal wire on WIF wiring harness to 4" (101.60 mm) green signal wire on WIF LED. Use additional green wire as needed.

- Locate 12 VDC or 24 VDC power source. Run red wire from power source to 4" (101.60 mm) red wire on WIF LED. Add a 1 A in-line fuse (not included). (See Figure 3.)

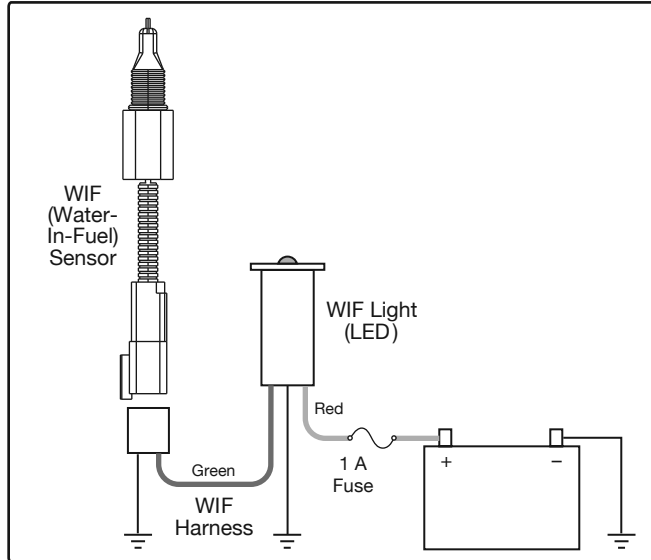

Figure 3 - WIF Wiring

Note: Use appropriate connectors to attach the wires. To test the WIF indicator, pour water into the body of the fuel processor until it covers the WIF probe. The WIF LED should illuminate. The volume of fluid necessary to turn the WIF indicator on is 1500 ml.

Installing an Optional Electric Pre-heater

Note: Drain the unit before installing or servicing any components on the unit.

All units come with pre-drilled ports to allow for pre-heaters (dual/duplex units require two pre-heaters):

- Single Short: One port
- Duplex Short: Two ports (one per body)
- Single Tall: Two ports
- Duplex Tall: Four ports (two per body)
- Dual Tall: Four ports (two per body)
- Triple Tall: Six ports (two per body)

Table 1 – 12 and 24 VDC Pre-heaters

Part Number	Description
SP1312	12 VDC Pre-heater
SP1313	24 VDC Pre-heater

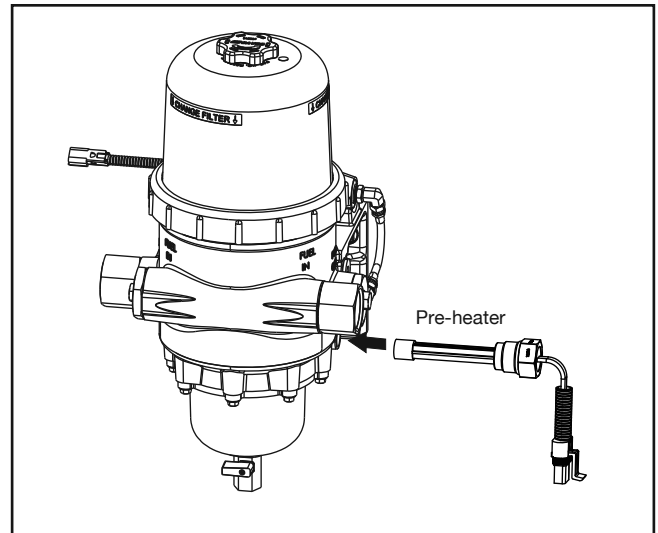

Figure 4 - Pre-heater Installation

To install, thread the pre-heater into housing and torque to 15-30 ft-lbs (20.3-40.7 N-m). Follow the wiring diagram in Figure 5.

Refer to equipment owner's manual for more specific information related to wiring diagrams of the equipment to which the unit will be applied.

Note: When wiring the electric pre-heater, use a fuse NOT a circuit breaker.

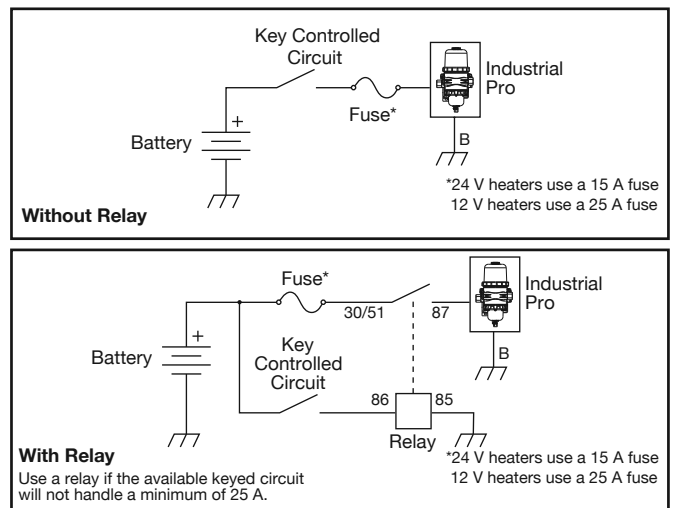

Figure 5 – Pre-heater Wiring Options

For systems with multiple Industrial Pro® units, the pre-heater power supply wiring must be split in the Junction Box. See Figure 6 for wiring a Dual system.

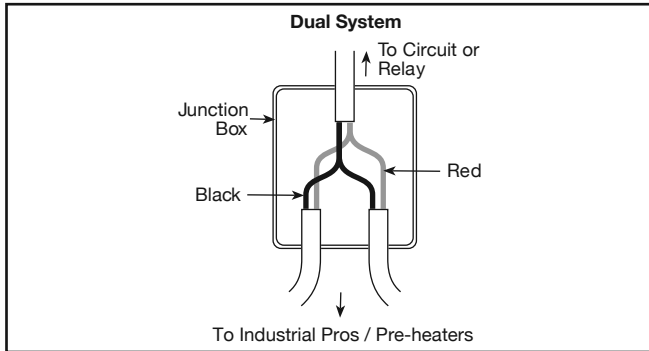

Figure 6 – Wiring Dual Filter Systems

Filter Change Procedure

Note: Change the filter only when the fuel level reaches and remains at the top of the black band on the filter. The filter may become dark, however, there is additional filter capacity and restriction will remain low until the fuel reaches the black band.

1. Turn off the engine.
2. Shut off the fuel supply to the unit you are working on if using a duplex unit (see the Valve Operation section).
3. Remove the vent cap and dispose of the O-ring. Clean the threads of the vent cap and on the top of the cover. Set the vent cap aside.
4. Open the drain valve and drain the fuel completely from the unit, then close the drain valve. The unit must be completely drained to prevent contamination of the clean side of the filtration system.
5. Using the Collar Wrench (part number SP1076), loosen the collar.
6. Remove the clear cover and collar from the Industrial Pro. Discard the cover O-ring and install a new O-ring (supplied with the filter) on the cover.
7. Clean the threads on the collar and body of the Industrial Pro.

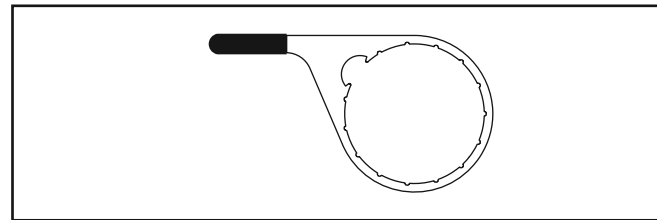

Figure 7 – Collar Wrench

8. Install the new O-ring on the vent cap (supplied with the filter).
9. Remove the filter element(s) from the Industrial Pro by pulling upward.
10. Install the new filter element. Figure 8 shows a key on the filter which fits into a keyway on the center boss. Position the filter element so the filter element key is lined up with the keyway on the center boss of the housing and press the filter element into the housing. Ensure the filter element is fully seated by firmly pushing on the top end plate.

Table 2 – Industrial Pro Replacement Filters

Part Number	Description
FS53014	EleMax™ NanoNet™ 5 micron (tall)
FS53015	EleMax NanoNet 5 micron (short)

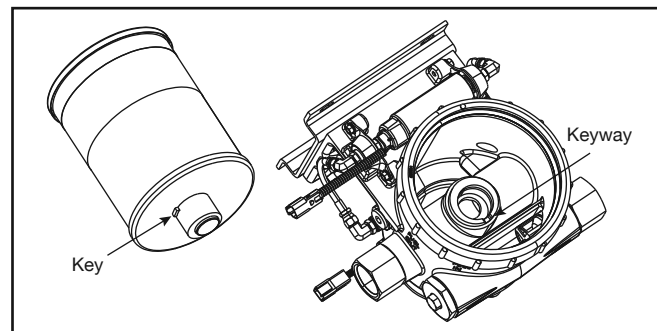

Figure 8 – Key and Keyway

11. After checking to make sure the new O-ring seal is seated correctly on the base of the cover, install the cover and collar. Simultaneously apply modest pressure to the top of the cover and turn the collar until it no longer spins freely.
12. Using the collar wrench, tighten the collar the distance of two additional ribs.
13. Prime the fuel system according to the steps in the "Priming the Fuel System" section in this manual. (The vent cap will be returned to the Industrial Pro during the priming process).

Valve Operation (DUPLEX UNIT ONLY)

1. For single unit flow, rotate both valve handles either to the left or right, depending on which unit is being used. Point the handle toward the unit you want to isolate. See Figure 9.
2. For dual flow, rotate the valve 180° from the shutoff position. See Figure 9.
3. To shut off flow, rotate the valve handle 180° from the dual flow position. See Figure 9.

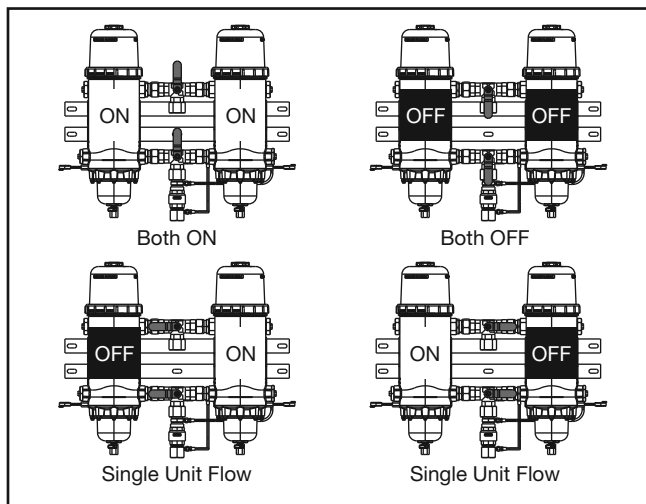

Figure 9 – Valve Operation

"On the Fly" Filter Change Requirements (DUPLEX UNIT ONLY)

- ⚠ WARNING:** Filter changes require the housing to be isolated from fuel flow. Do not attempt to change the filter on the active housing during engine operation.
4. If the Duplex unit is being used in Duplex mode:
 - a. Rotate both valve handles into the Dual Mode position (Both ON) until fuel is flowing through both units. See Figure 9.
 - b. Rotate both handles to isolate the unit that requires the filter change. The handles should now point to this unit. See Figure 9.
 - c. Follow the filter change procedure.
 2. If the Duplex unit is being used in Dual mode:
 - a. Bring the engine to idle before servicing the units.

- b. Rotate both valve handles to isolate either the left or right unit. The Duplex unit is now in Dual mode. See Figure 9.
- c. Follow the filter change procedure to service the isolated unit.
- d. After the filter change procedure is complete for this unit, rotate both valve handles into the Dual Mode position (Both ON) until fuel is flowing through both units. See Figure 9.
- e. Rotate both valve handles to isolate the other unit that requires filter change. The valve handles should now point to this unit. See Figure 9.
- f. Follow the filter change procedure.

Priming the Fuel System

⚠ CAUTION: Running the priming pump dry for more than 30 seconds can cause the pump to fail and void the warranty. Follow the steps in this section to prevent pump damage.

1. Check to make sure the drain valve at the base of the Industrial Pro® is closed.
2. Close the fuel shutoff valve (if equipped). If using a duplex unit, shut off the fuel supply to the unit you are working on.
3. Remove the vent cap from the top of the clear cover.
4. Fill the Industrial Pro full of fuel.
5. Tighten the vent cap (**tighten by hand only**) until it "clicks."
6. Open the fuel shutoff valve and/or duplex valves (if equipped).
7. Start the engine.
8. When the lubrication system reaches its normal operating pressure, increase engine speed to high idle for one to two minutes.
9. Loosen the vent cap until the fuel level drops to just above the collar.
10. Tighten the vent cap (**tighten by hand only**) until it "clicks."

Note: The clear filter cover will not fill completely during engine operation. It will gradually fill over time and the fuel level will rise as the filter becomes clogged.

Draining Water Contaminants

1. Shut off the fuel supply to the housing that requires draining and open the vent cap.
2. Place a suitable container under the drain valve at the base of the Industrial Pro and open the drain valve.
3. Water and contaminants will flow into the container. When fuel begins to flow out of the drain, close the drain valve.
4. Tighten the vent cap by hand until it “clicks.”
5. Start the engine. Raise the RPM for one minute to purge the air from the system.

Servicing the Primer Pump

1. Remove the fitting on the end of the pump using two wrenches to hold the end stationary as the fitting is loosened.
2. The washer on the fittings **MUST** be in place when reassembled.

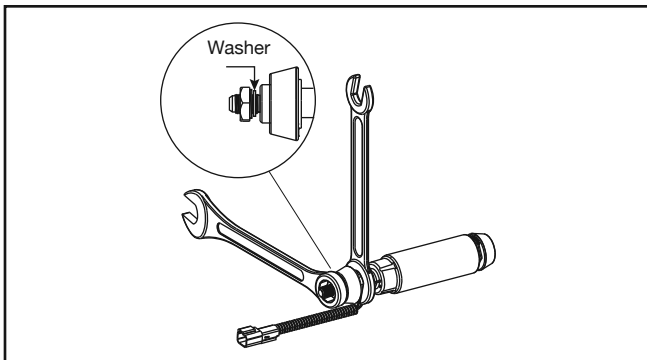

Figure 10 – Removing the Primer Pump Fitting

Suggested Preventive Maintenance

Weekly – Drain water.

Every Filter Change – Change o-rings.

Every 12 Months – Check all electrical connections for corrosion. Check all fuel fittings for leaks.

Extreme winter or salt corrosion environments may require lubrication of the top collar threads with anti-seize lubricant every 180 days.

Changing the Fuel Inlet Direction for Industrial Pro Single and Dual Configurations

To change the fuel inlet from the left to right, or from the right to left, exchange the inlet fitting (including check valve) with the threaded plug on the opposite side of the housing. Torque both of the fittings to 55-65 ft-lb (74.6-88.1 N-m).

Changing the Fuel Outlet Direction for Single Configurations Only

Note: Drain the unit before installing or servicing any components on the unit.

To change the fuel outlet from the left to right, or from the right to left, both the fittings and the priming pump require a directional change as follows:

1. Remove the outlet fitting with the bypass valve attached.
2. Remove the outlet plug from the opposite side of the housing.
3. Exchange the fitting and plug to the opposite sides and torque to 55-65 ft-lb (74.6-88.1 N-m). Ensure the bypass valve head is seated correctly.
4. Disconnect the hoses attaching the priming pump to the housing.
5. Remove the bolts securing the priming pump straps.
6. Turn the priming pump to ensure that the arrow etched on the pump housing is pointed in the direction of the outlet of the housing.
7. Reinstall bolts securing the priming pump straps and torque to 8-10 ft-lb (10.8-13.6 N-m).
8. Reinstall the hoses and torque to 10-15 ft-lb (13.6-20.3 N-m).

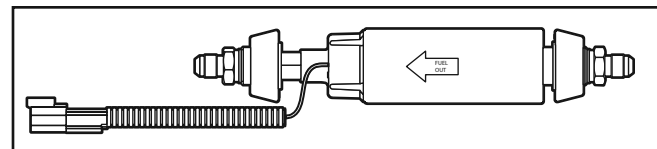

Figure 11 – Primer Pump Fitting

Changing the Fuel Outlet Direction for Dual and Triple Configurations Only

The same procedure applies to the dual and triple configuration as with the single configuration, but the priming pump must also be moved to the housing with the fuel outlet fitting attached. Again, ensure the flow direction arrow is pointed toward the outlet fitting.

For instance, if changing from a fuel out left configuration to a fuel out right configuration, the priming pump must be moved from the left housing to the right housing.

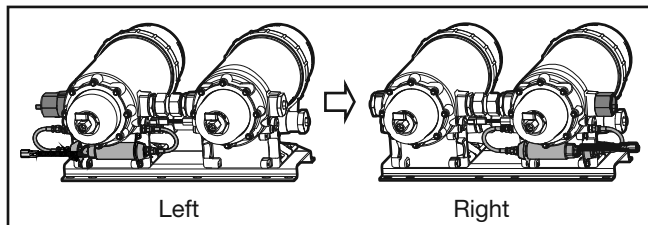
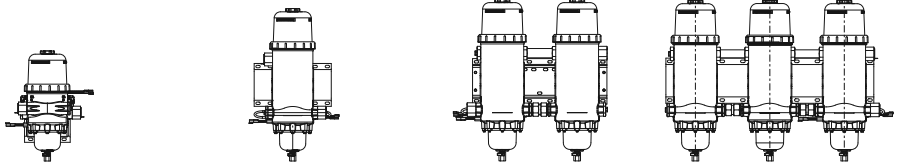

Figure 12 – Changing From a Fuel Out Left to a Fuel Out Right Configuration

Torque Values

Application	Torque		
	in-lb	ft-lb	N•m
WIF Probe to Housing	20-24	1.67-2.0	2.3-2.7
Fuel Connection Fittings to Housing Body		55-65	74.6-88.1
Pre-heater to Housing		15-30	20.3-40.7
Drain Valve to Bowl		10-15	13.6-20.3
Primer Pump Strap to Body		8-10	10.8-13.6
Primer Pump Fittings to Housing Body		13-15	17.6-20.3
Pump Inlet/Outlet Hose to Fittings		10-15	13.6-20.3
Assembly to Mounting Bracket		35-50	47.5-67.8
Collar to Bottom Bowl		8-10	10.8-13.6

Industrial Pro® Specifications



Specification	Single Short	Single Tall	Dual Tall	Triple Tall
Height Overall	20" (508 mm)	28" (711 mm)	28" (711 mm)	28" (711 mm)
Depth Overall	12" (305 mm)	12" (305 mm)	12" (305 mm)	12" (305 mm)
Width, max	11.2" (284 mm)	13.9" (352 mm)	23.8" (604 mm)	35.5" (902 mm)
Weight (Dry)	29 lbs (13.2 kg)	39 lbs (17.7 kg)	75 lbs (34.0 kg)	151 lbs (68.5 kg)
Weight (Wet)	37 lbs (16.8 kg)	57 lbs (25.6 kg)	112 lbs (50.8 kg)	213 lbs (96.6 kg)
Fuel Capacity (w/o filter)	1.1 gal (4.3 L)	2.5 gal (9.5 L)	5.0 gal (19 L)	7.5 gal (28.5 L)
Fuel Connections	1-1/4" NPT	1-1/4" NPT	1-1/4" NPT	1-1/4" NPT
Fuel Flow Rate	300 gal/hr (18.9 L/min)	600 gal/hr (37.9 L/min)	1200 gal/hr (75.7 L/min)	1200 gal/hr (75.7 L/min)
Bottom Bowl Water Holding Capacity	29 fl oz (857 ml)	29 fl oz (857 ml)	58 fl oz (1715 ml)	87 fl oz (2573 ml)
Filter Service Clearance	Min. 3.5" (89 mm)	Min. 6.0" (152 mm)	Min. 6.0" (152 mm)	Min. 6.0" (152 mm)
Electrical Pre-heater Options	12 VDC or 24 VDC			
Primer Pump	Supply Voltage: 24 VDC, 6 A			
Fuel Types	Compatible for use with Diesel #1, Diesel #2, Kerosene, Biodiesel B20, and JP8			



Specification	Duplex Short	Duplex Tall
Height Overall	20" (508 mm)	28" (711 mm)
Depth Overall	12.4" (314 mm)	12" (305 mm)
Width, max	32" (813 mm)	32" (813 mm)
Weight (Dry)	71 lbs (32.2 kg) w/ check valve 66 lbs (29.9 kg) w/o check valve	91 lbs (41.3 kg) w/ check valve 86 lbs (39.0 kg) w/o check valve
Weight (Wet)	87 lbs (39.5 kg) w/ check valve 82 lbs (37.2 kg) w/o check valve	127 lbs (57.6 kg) w/ check valve 122 lbs (55.3 kg) w/o check valve
Fuel Capacity (w/o filter)	2.2 gal (8 L)	5.0 gal (19 L)
Fuel Connections	1-1/4" NPT	1-1/4" NPT
Fuel Flow Rate	300 gal/hr Duplex mode (18.9 L/min) 600 gal/hr Dual mode (37.9 L/min)	600 gal/hr Duplex mode (37.9 L/min) 1200 gal/hr Dual mode (75.7 L/min)
Bottom Bowl Water Holding Capacity	29 fl oz (857 ml) Single mode 58 fl oz (1715 ml) Dual mode	29 fl oz (857 ml) Single mode 58 fl oz (1715 ml) Dual mode
Filter Service Clearance	Min. 3.5" (89 mm)	Min. 6.0" (152 mm)
Electrical Pre-heater Options	12 VDC or 24 VDC	
Primer Pump	Supply Voltage: 24 VDC, 6 A	
Fuel Types	Compatible for use with Diesel #1, Diesel #2, Kerosene, Biodiesel B20, and JP8	

Specifications subject to change without notice.

Dimensions

Industrial Pro® Single Short

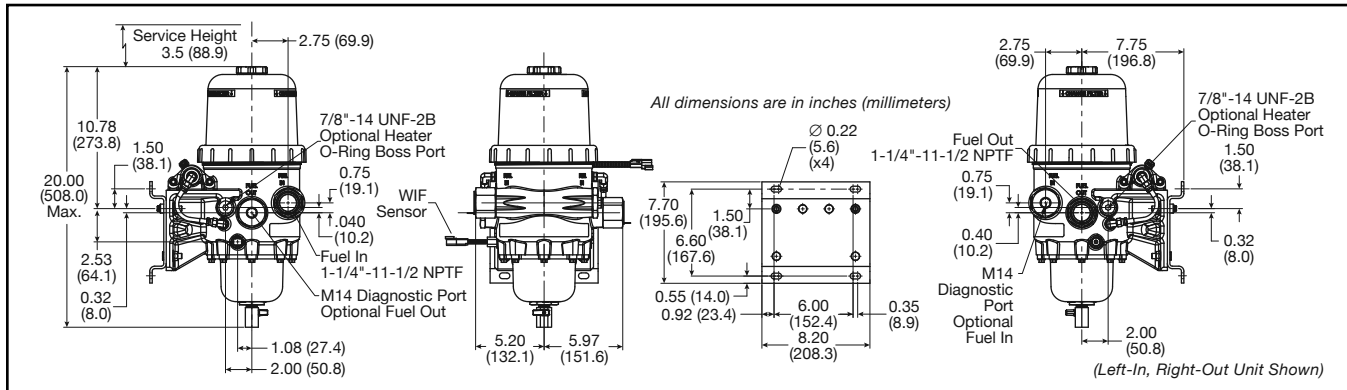

Industrial Pro® Single Tall

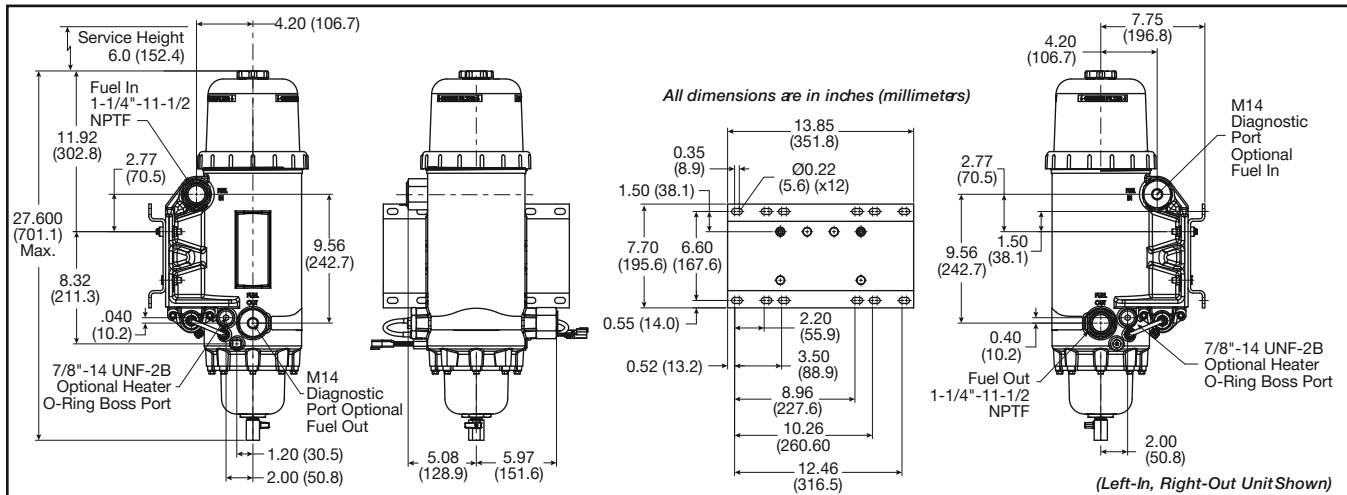

Industrial Pro® Dual Tall

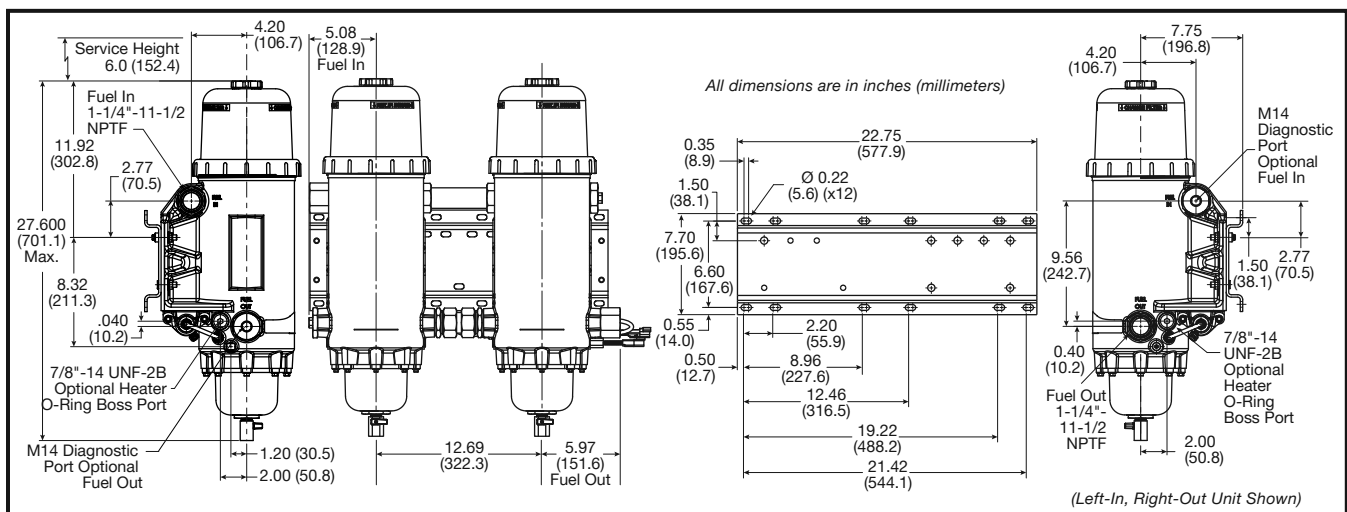

Dimensions

Industrial Pro® Duplex Short

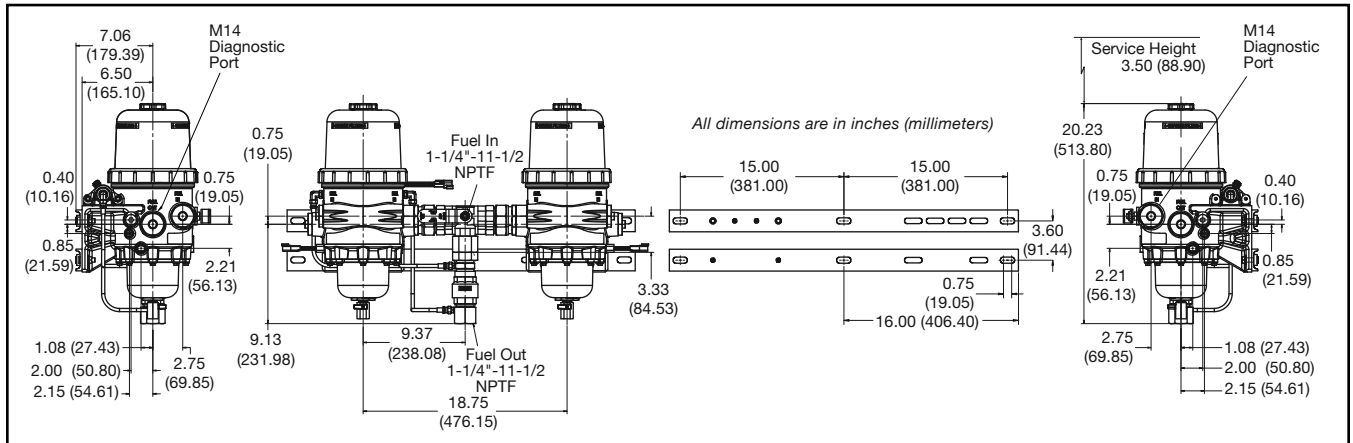

Industrial Pro® Duplex Tall

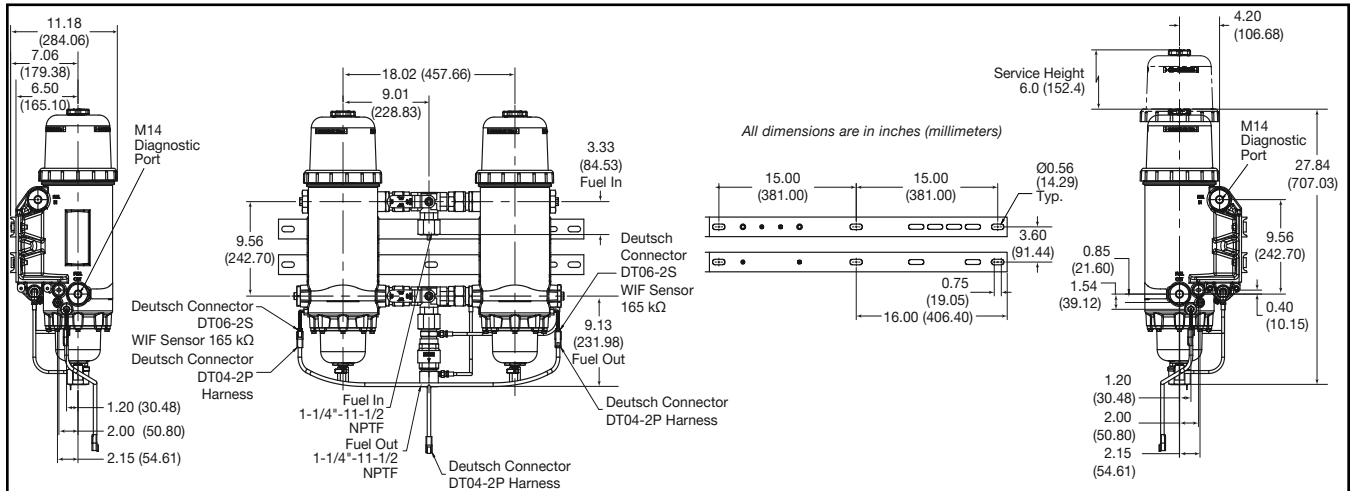

Industrial Pro® Triple Tall

