

# FUEL PRO<sup>®</sup> 382

## PRODUCT DATA SHEET

**DAVCO FUEL PRO 382** is an all-in-one fuel filter, water separator, and fuel pre-heater for heavy duty on-highway diesel engines with flow rates up to 180 gallons per hour.

The Fuel Pro 382, with an optional pre-heater, overnight heater and water-in-fuel sensor will keep the engine running in any weather conditions.

“SEEING IS BELIEVING”<sup>®</sup> functionality and the clear cover on top provides enhanced fuel system troubleshooting and a clear indication of when to change the fuel filter.

### Applications

- Diesel engines with flow rates up to 180 gph

### Models and Options

- Base Model - Unheated
- Coolant Heat/Return Fuel Heat
- Electric Heat
  - 12VDC or 24VDC Pre-heater
  - 120VAC Overnight heater
- Water-In-Fuel (WIF) sensor
- 7-10-25-50 micron filter

### Typical Installation

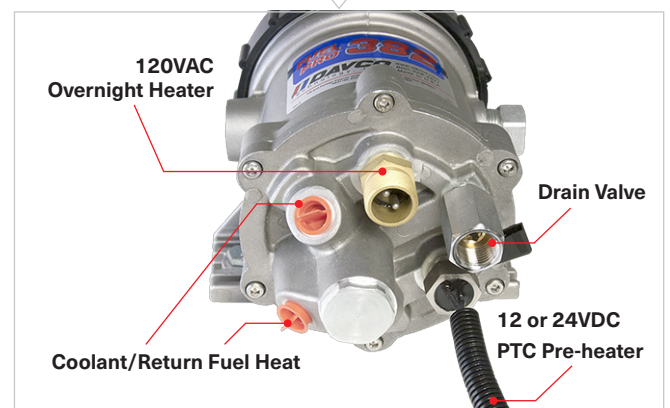
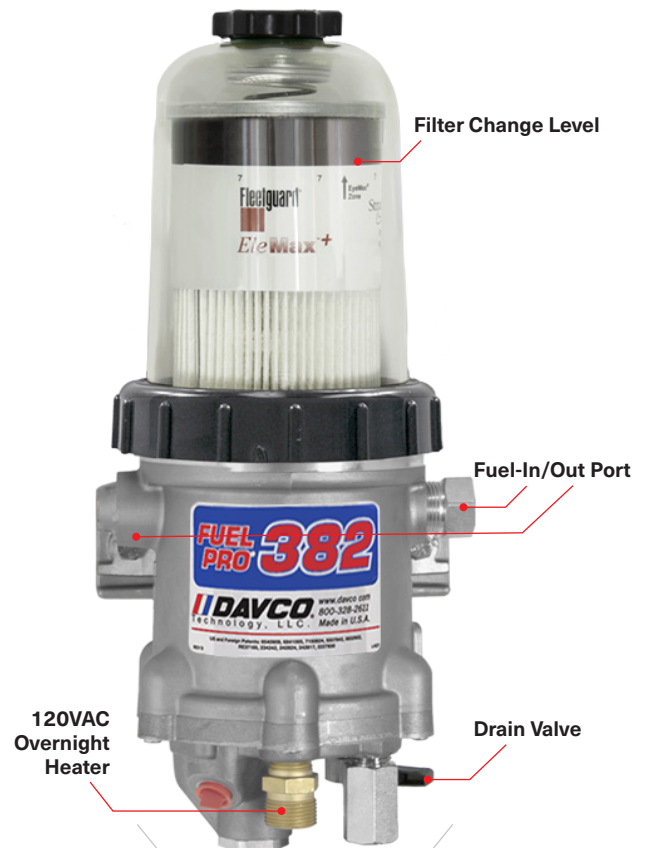
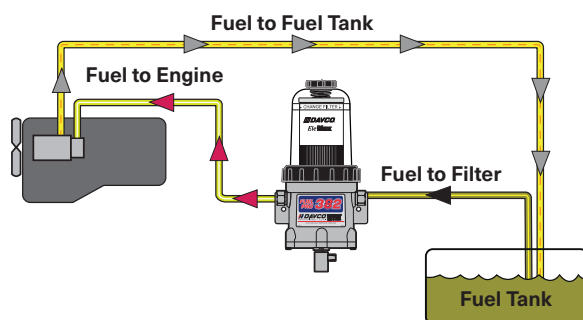

A **Clariance Technologies** Company

**DAVCO Technology, LLC**

1600 Woodland Drive, Saline, MI 48176-1629

800-328-2611

customerservice@davco.com

www.davco.com

# FUEL PRO® 382

## Specifications

Height, Overall (Unheated)	15.5 in. (393.6 mm)
Height, Overall (Coolant/Return Fuel Heat)	16.25 in. (412.8 mm)
Depth, Overall	6.63 in. (168.5 mm)
Width, Maximum	7.3 in. (185.2 mm)
Weight, Dry	Approx. 8-12 lbs
Filter Service Clearance, Minimum	1.5 in. (38.1 mm)
Fuel Flow, Maximum	180 gph
Pre-heater	12VDC, 195W, 155W 24VDC, 195W
Overnight heater	120VAC, 75 W, .65 A

## Filtration Performance (100 GPH)

Micron	Coarse Water Removal (%)	Emulsified Water Removal (%)	Dirt Holding Capacity (grams)
7	99.4	>95	56
10	99.9	>95	64
25	99.6	>95	110
50	97	<20	90

## Port Interface

Fuel In	½"-14 NPTF
Fuel Out	½"-14 NPTF

## Dimensions, Unheated

Dimensions are in inches [millimeters]

Mounting Hole Distance: 5.91 [150]

Mounting Hole Openings: .43 [11]

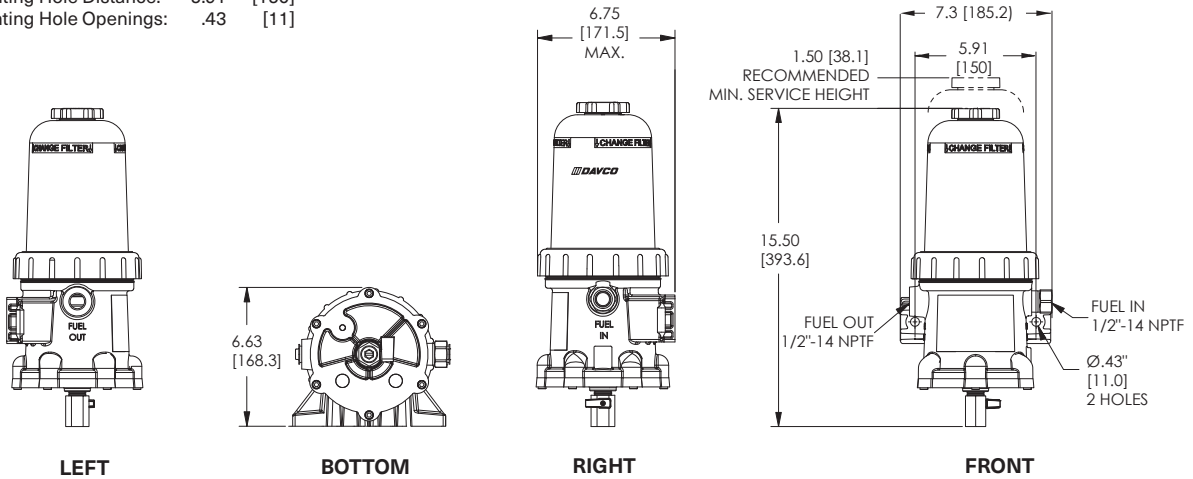

## Dimensions, Coolant/Return Fuel Heat

Dimensions are in inches [millimeters]

Mounting Hole Distance: 5.91 [150]

Mounting Hole Openings: .43 [11]

