

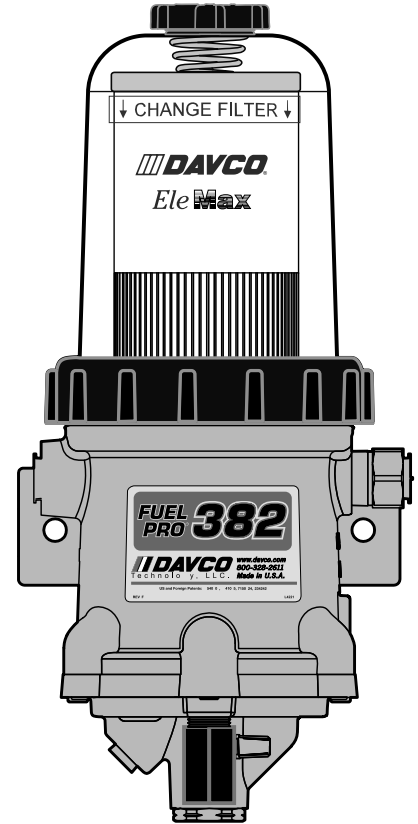

A Clarience Technologies Company

TABLE OF CONTENTS

Applications, Models, and Options... 1
SEEING IS BELIEVING... 2
Dimensions and Specifications (Without Fluid Heat)... 3
Dimensions And Specifications (With Coolant Or Return Fuel Heat)... 4
Important Safety Precautions... 5
Installation Instructions... 6
Priming the Fuel System... 7
Water-in-Fuel (WIF) Sensor Installation... 7
120VAC Overnight heater Installation... 8
12 or 24VDC Pre-heater Installation... 9
Coolant Heat Installation... 10
Return Fuel Heat Installation... 11
Visual Diagnostics-Air vs. Vapor Bubbles... 12
Diagnostic Procedures for Air Leaks... 13
Visual Diagnostics with Clear Cover... 14
Diagnostic Procedures For Coolant Or Return Fuel Heat Thermo Valve... 15
Return Fuel Heat Diagnostics... 15
Diagnostic Procedures For Pre-heater/Overnight Heaters... 16
Filter Change Procedure... 17
Preventative Maintenance... 18
Check Valve Service... 19
Service Part Numbers... 20
Warranty Policy... 24
Parts Return General Policy... 25



FOR UPDATED INFORMATION VISIT WWW.DAVCO.COM

FUEL PRO 382 TECHNICAL MANUAL

APPLICATIONS, MODELS, AND OPTIONS

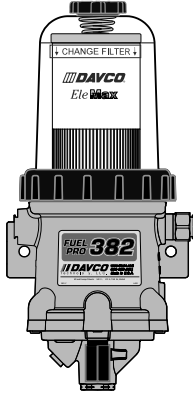

The Fuel Pro 382 combines the features of fuel filtration, fuel/water separation and fuel filter preheating into a single unit. It is intended for any diesel engine with:

- Flow rates up to 180 GPH
- Biodiesel/Renewable Fuel Compatibility

Applications

- Class 7 and 8 Trucks

Models and Options

- Base Model-Unheated
- 12VDC or 24VDC Pre-heater
- 120VAC Overnight heater
- Water-In-Fuel (WIF) Sensor
- Coolant Heat
- Return Fuel Heat

HOW IT WORKS

- Fuel from the tank enters the Fuel Pro body (suction side of the fuel system).
- Large contaminants and “free” water are separated from the fuel and remain in the body.
- Fuel rises into the clear cover.
- Contaminants and emulsified water are captured by the filter media.
- Fuel level continues to rise to maintain a fuel path through the clean filter media with low restriction.
- Clean, water-free fuel exits the Fuel Pro and flows to the engine fuel injection system.

Fuel System Diagram

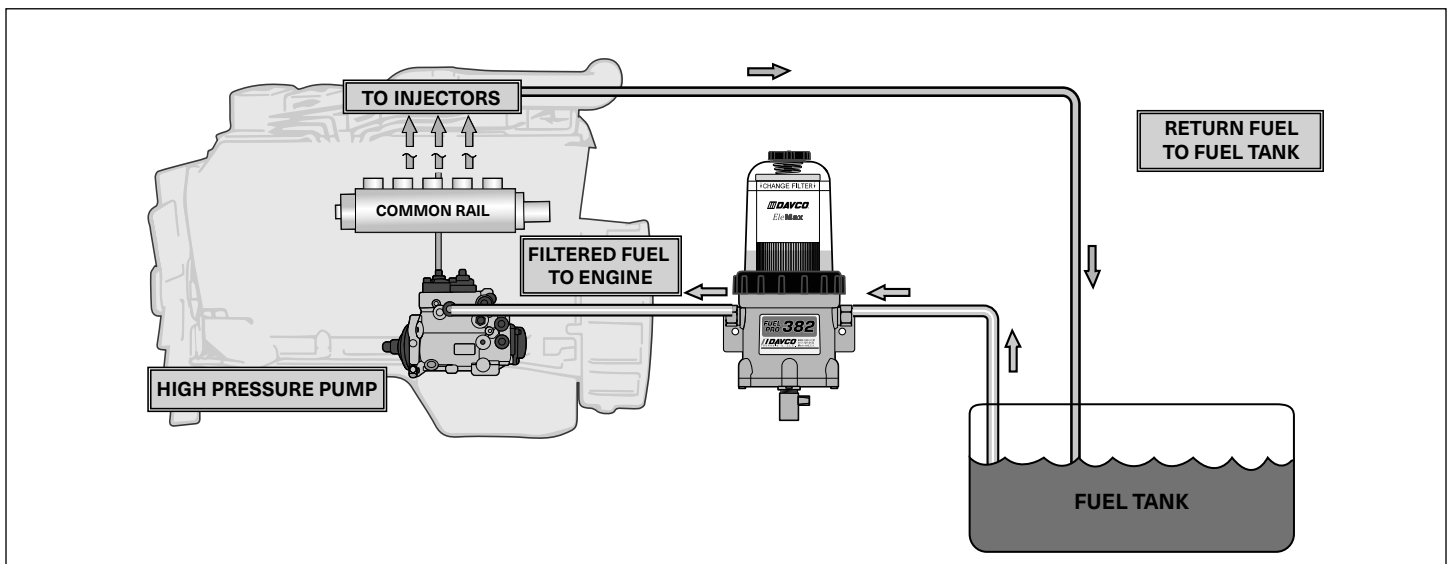

“SEEING IS BELIEVING”®

See when NOT to change the fuel filter.

See the condition of the fuel. Seeing what collects on the filter media or what’s happening inside the clear cover can help diagnose many fuel and mechanical conditions.

“Filter on Top” configuration. Water and debris removed from the fuel falls to the lower chamber and stays away from the filter media resulting in longer filter life.

Built in protection when priming the fuel filter. Unfiltered fuel is kept on the “dirty” side of the filter media during priming ensuring only clean fuel reaches the engine.

Patented media. The “Best in Class” StrataPore® media removes 98% of free and emulsified water. This far exceeds the performance of cellulose media.

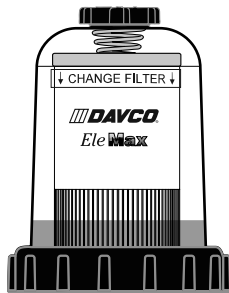

When new, the fuel level in the filter will be very low with minimal restriction. As the filter is used, contaminants collect on the filter from the bottom up. Fuel rises on the filter indicating remaining filter life.

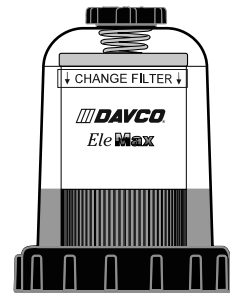

Fuel level at filter wrap level. Even though the fuel level is now more than half of the filter element, the fuel is still flowing through clean media at minimal restriction levels. The filter still has significant life remaining.

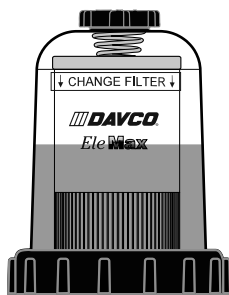

Fuel level increases in clear cover. As contaminants collect on the filter, the fuel rises to a non-contaminated section of the filter, providing optimal filtration while maintaining lowest restriction.

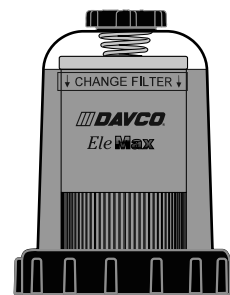

The filter element is now completely covered by fuel. At this point, all of the media’s surface area is utilized. Restriction is increasing and the filter element should be changed at the next scheduled maintenance interval.

DIMENSIONS AND SPECIFICATIONS (WITHOUT FLUID HEAT)

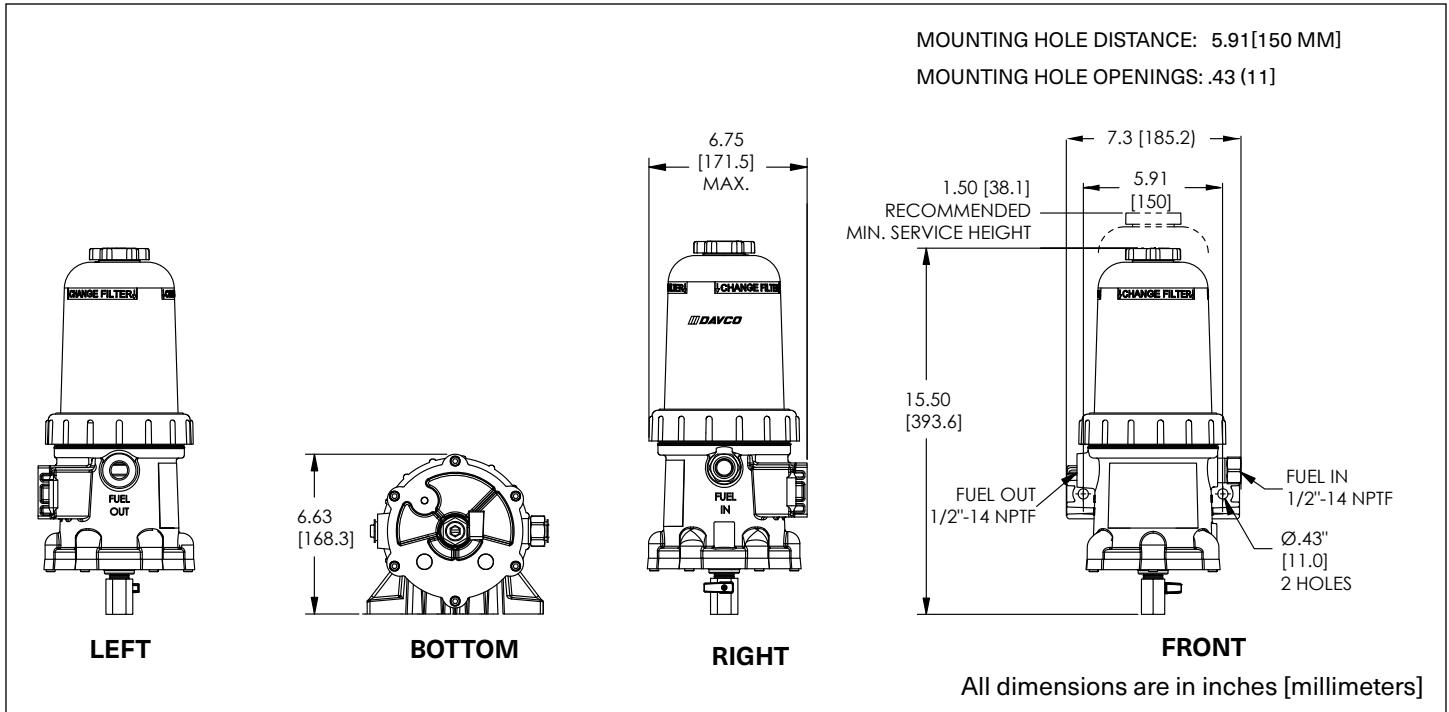

SPECIFICATIONS

Height, Overall	15.50 in (393.6 mm)
Depth, Overall	6.63 in (168.5 mm)
Width, Maximum	7.3 in (185.2 mm)
Mount Bracket Centers	5.91 in (150 mm)
Weight, dry	Approx. 8-12 lbs
Recommended Minimum Service Height	1.5" (38.1 mm)
Fuel Flow, Maximum	180 gph
Pre-heater	12VDC, 195W, 155W 24VDC, 195W, 155W
Overnight heater	120VAC, 75W

PORT INTERFACE

Fuel In Connection	1/2"-14 NPTF
Fuel Out Connection	1/2"-14 NPTF

FILTRATION PERFORMANCE AT 100 GPH

Micron	Coarse Water Removal (%)	Emulsified Water Removal (%)	Dirt Holding Capacity (grams)
7	99.4	>95	56
10	99.9	>95	64
25	99.6	>95	110
50	97	<20	90

RESTRICTION VS. FLOW

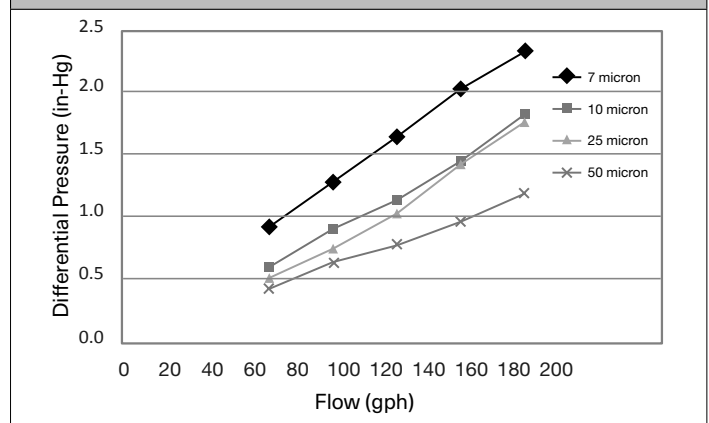

DIMENSIONS AND SPECIFICATIONS (WITH COOLANT OR RETURN FUEL HEAT)

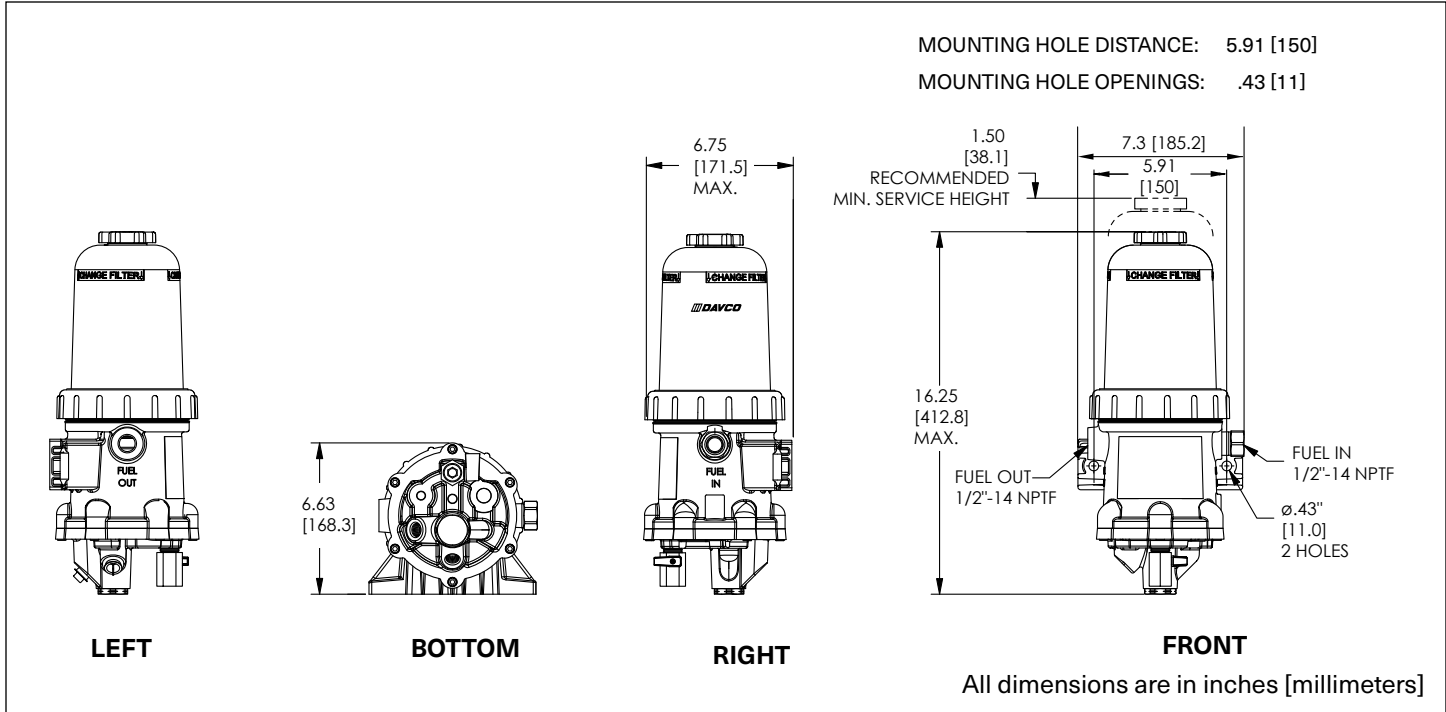

SPECIFICATIONS	
Height, Overall	16.25 inches (412.8 mm)
Depth, Overall	6.63 inches (168.5 mm)
Width, Maximum	7.3 inches (185.2 mm)
Mount Bracket Centers	5.91 inches (150 mm)
Weight, Dry	Approx. 8-12 lbs
Recommended Minimum Service Height	1.5" (38.1)
Max Fuel Flow	180 gph
Pre-heater	12VDC, 195W, 155W 24VDC, 195W, 155W
Overnight heater	120VAC, 75W

PORT INTERFACE	
Fuel In Connection	1/2"-14 NPTF
Fuel Out Connection	1/2"-14 NPTF

FILTRATION PERFORMANCE AT 100 GPH			
Micron	Coarse Water Removal (%)	Emulsified Water Removal (%)	Dirt Holding Capacity (grams)
7	99.4	>95	56
10	99.9	>95	64
25	99.6	>95	110
50	97	<20	90

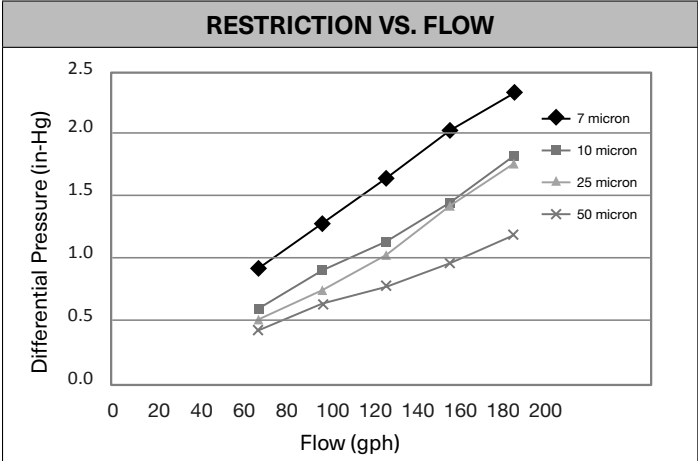

⚠ IMPORTANT SAFETY PRECAUTIONS

General Safety Precautions

- **FOR USE WITH DIESEL FUEL ONLY**
- To avoid serious injury or death, follow the safety information in this document.
- Keep this manual. If you need to replace the manual, call customer service at 800-328-2611 or visit www.davco.com for a replacement.
- Refer to appropriate regulations for environmental and workplace safety rules.

WARNING: To prevent personal injury

- **Scalding hazard:** When diesel fuel is circulated through an operating engine, it can become very hot. Do not allow fuel to come in contact with eyes or unprotected skin. Allow the engine and fuel to cool to ambient temperature before replacing the fuel filter or performing service operations which could result in spillage of fuel from the fuel system.
- **Fire Prevention:** Heated fuel can form combustible vapor mixtures in the area around the fuel source. To eliminate the potential for fire, keep open flames, sparks or other potential ignition sources away from the work area. Do not smoke during filter replacement or service operations.
- **Inhalation Precaution:** Always perform engine or vehicle fuel system maintenance in a well ventilated area that is kept free of bystanders.
- The ignition key must be in the **off** position, unless otherwise directed. To avoid unintentional engine startup, use a lockout key and/or signage to alert personnel that work is being performed.
- Do not energize the pre-heater outside of the Fuel Pro. It can become very hot.

Government Regulations

- Engine fluids (oil, fuel, and coolant) may be a hazard to human health and the environment. Handle all fluids and other contaminated materials (such as filters and rags) in accordance with applicable regulations. Recycle or dispose of engine fluids, filters, and other contaminated materials according to applicable regulations.

INSTALLATION INSTRUCTIONS

Installation Location

The Fuel Pro must be installed between the fuel tank and the fuel transfer pump. In some cases, the Fuel Pro can be used as the only fuel filter in the system. This is generally dependent on the engine model year. Consult the engine manufacturer for their recommendation.

- **Do not install the Fuel Pro directly on the engine.**
- Mount vertically with the cover and element pointing up.
- Make sure there is enough top and side clearance for the cover to be conveniently removed for filter replacement (3.5" minimum).
- The Fuel Pro **MUST** be installed so that the filter element is above the "FULL" level of the fuel tank. If mounted below full tank level, a shut off valve will be required at the inlet to allow filter changes without overflow of fuel.

⚠ **The ignition key must be in the off position. To avoid unintentional engine startup, use a lockout key and/or signage to alert personnel that work is being performed. Chock the wheels.**

1. With the engine shut down and at ambient temperature, close the fuel shutoff valve (if equipped) and place a suitable container under the fuel filters.
2. Drain and remove the primary fuel filter element assembly, sedimenter, and/or water separator. Dispose of it in an environmentally responsible manner.
3. Mount the Fuel Pro in the desired location using 3/8" Grade 8 bolts.

Painting Precautions

The collar/cover joint and threads are designed to be free of paint in order to function properly. The cover and collar assembly must be completely masked off if the Fuel Pro is to be painted.

Fuel Line Routing

To minimize fuel system restriction, observe the following guidelines when plumbing the fuel system:

- Keep the fuel line routing as smooth as possible with no low-hanging loops which can trap water.
 - Use 90° elbows only when necessary.
 - If the fuel hoses are cut to length on site, be sure that the inner liner of the fuel hose is not cut by the fitting, which can cause check valve performance issues. Make sure hoses are clean and free of debris before installing.
 - To avoid damaging the aluminum Fuel Pro body, do not over-tighten fuel lines or fuel line fittings.
1. Route the fuel supply line from the pick up on the fuel tank to the Fuel Pro inlet (labeled "FUEL IN" on the housing).
 2. Route the fuel outlet line from the Fuel Pro outlet (labeled "FUEL OUT" on the housing) to the inlet of the fuel pump.

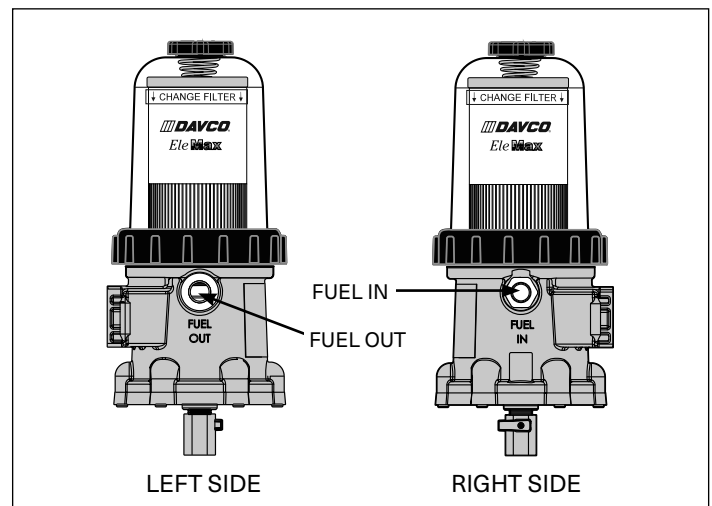

PRIMING THE FUEL SYSTEM

1. Ensure that the drain valve at the base of the Fuel Pro is closed.
2. Remove the vent cap from the top of the clear cover. Fill the Fuel Pro with clean fuel. Install the vent cap and tighten it by hand until it clicks.
3. Start the engine. When the lubrication system reaches its normal operating pressure increase the engine RPM to high idle for one to two minutes.
4. After the air is purged **and while the engine is at idle**, loosen the vent cap and let the fuel level drop to just above the collar, then tighten the vent cap by hand until it clicks.

It is normal for the fuel level to vary after the initial start-up and during engine operation. Filter performance is not affected.

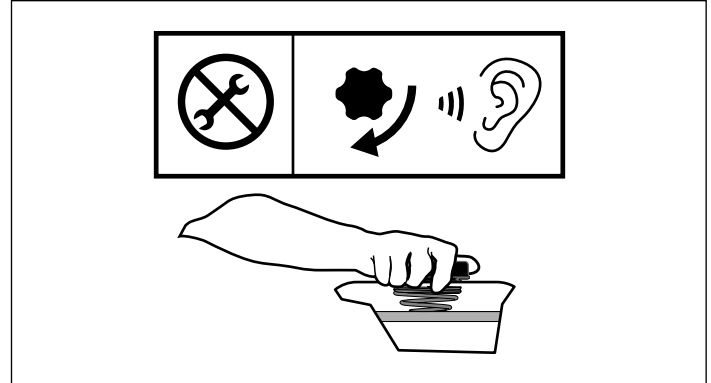

WATER-IN-FUEL (WIF) SENSOR INSTALLATION

1. Remove the vent cap. Open the drain valve. Drain the Fuel Pro completely. Close the drain valve. The fuel can be reused after the installation.
2. Remove the WIF or the plug.
3. Install the WIF into the WIF port. Torque to 20-24 in.-lb.
4. Prime the Fuel Pro and check for leaks.

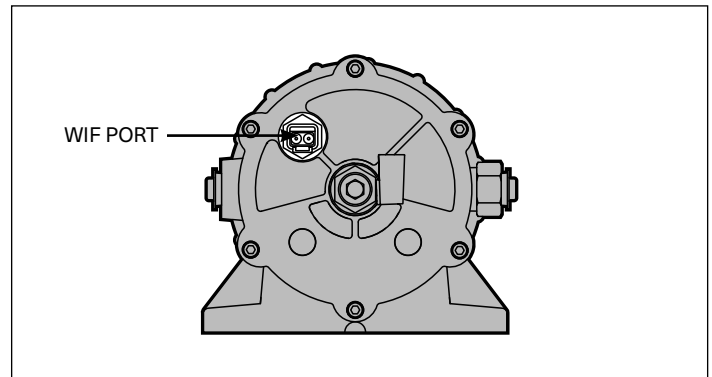

120VAC OVERNIGHT HEATER INSTALLATION

The 120VAC overnight heater is installed in the bottom of the Fuel Pro.

1. Remove the vent cap. Open the drain valve. Drain the Fuel Pro completely. Close the drain valve. The fuel can be reused after the installation.
2. Remove the overnight heater or plug from the heater port.
3. Apply liquid or paste type thread sealant to the heater threads and install the heater into the 120VAC overnight heater port on the Fuel Pro. Torque to 15-30 ft-lb.
4. Connect the "Y" cord to the overnight heater. Connect the other end of the harness to the engine block heater. Connect the cord to a 120VAC output location on the truck (usually located below the driver's door).
5. Prime the Fuel Pro (see page 7) and check for leaks.

The 120VAC Overnight Heater eliminates wax in cold weather.

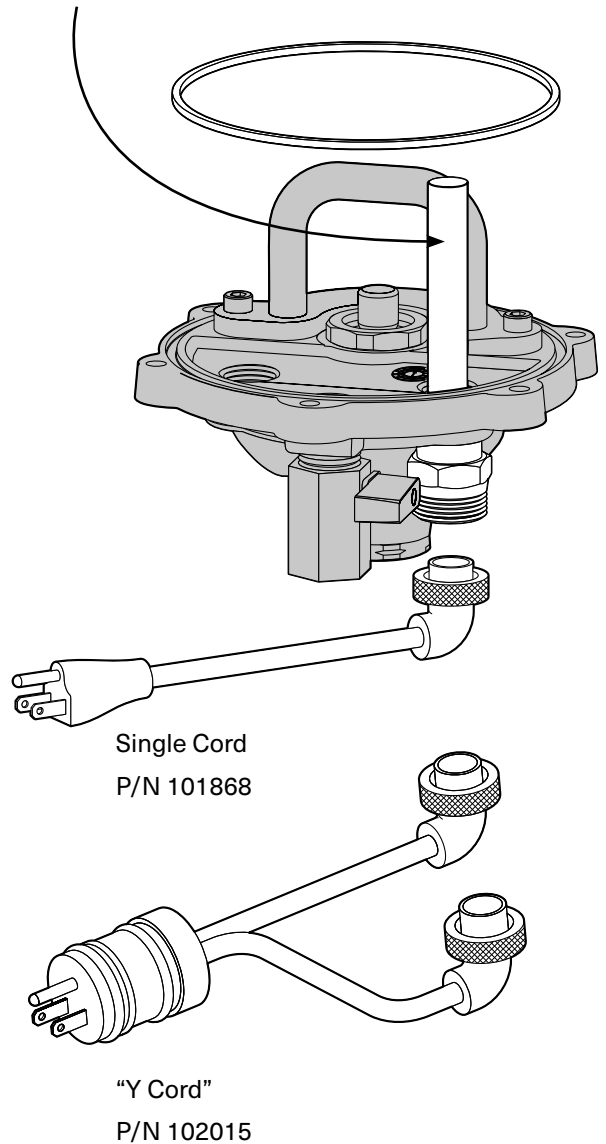

12 OR 24VDC PRE-HEATER INSTALLATION

The Fuel Pro 382 12VDC or 24VDC electric pre-heater is installed in the bottom plate.

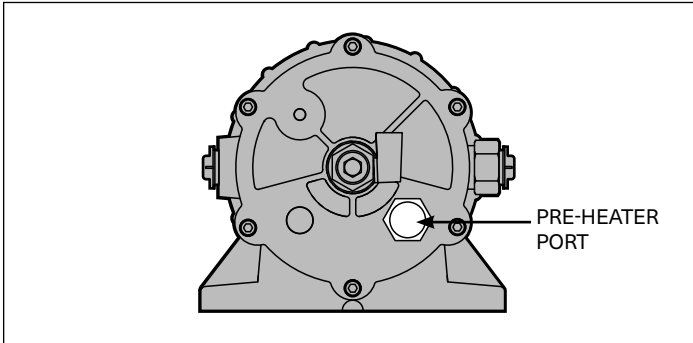

1. Remove the vent cap. Open the drain valve and drain the Fuel Pro completely.
2. Remove the plug or pre-heater from the Fuel Pro.
3. Apply liquid or paste type thread sealant to the pre-heater threads and install into the heater port. Torque to 15-30 ft-lb.
4. Prime the Fuel Pro (see page 7) and check for leaks.
5. Connect the chassis harness to the pre-heater harness.
6. Connect the power lead to the fused accessory side of the ignition switch. The fuse rating depends on the pre-heater installed.

Approved fuse ratings

The voltage and wattage ratings are stamped on the hex of the pre-heater for identification purposes.

- 12VDC System:
 - 20 amp fuse for a 155W PTC pre-heater
 - 25 amp fuse for a 195W PTC pre-heater
- 24VDC System:
 - 15 amp fuse for a 195W PTC pre-heater
- If the keyed circuit will not handle the required amperage for the pre-heater, install a relay as shown below.

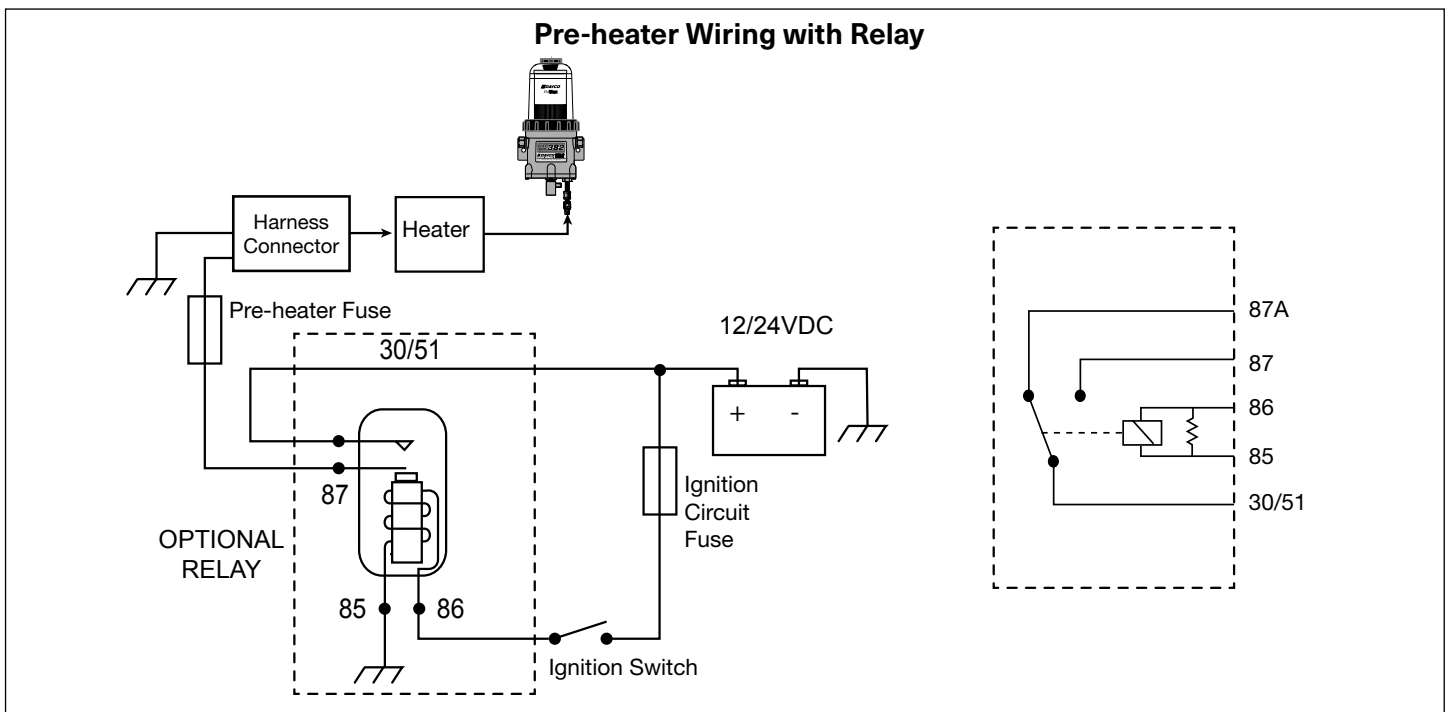

COOLANT HEAT INSTALLATION

Determine if the bottom plate is equipped with a fluid heat assembly. If the bottom plate is flat, it is not a fluid heated assembly. To upgrade to coolant heat, order the DAVCO coolant heat bottom plate upgrade kit, DAVCO P/N 382029-23DAV.

If the Fuel Pro 382 has a deep bottom plate, it is a fluid heated assembly with a heater loop and can be upgraded to use coolant heat. (Refer to form F3029 on www.davco.com for upgrade instructions).

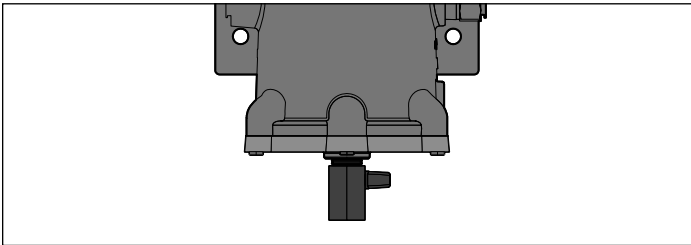

Flat Bottom Plate

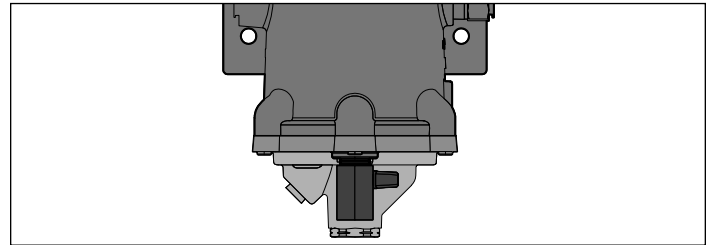

Coolant Heat Bottom Plate

Fuel System Diagram Showing Coolant Heat Connections

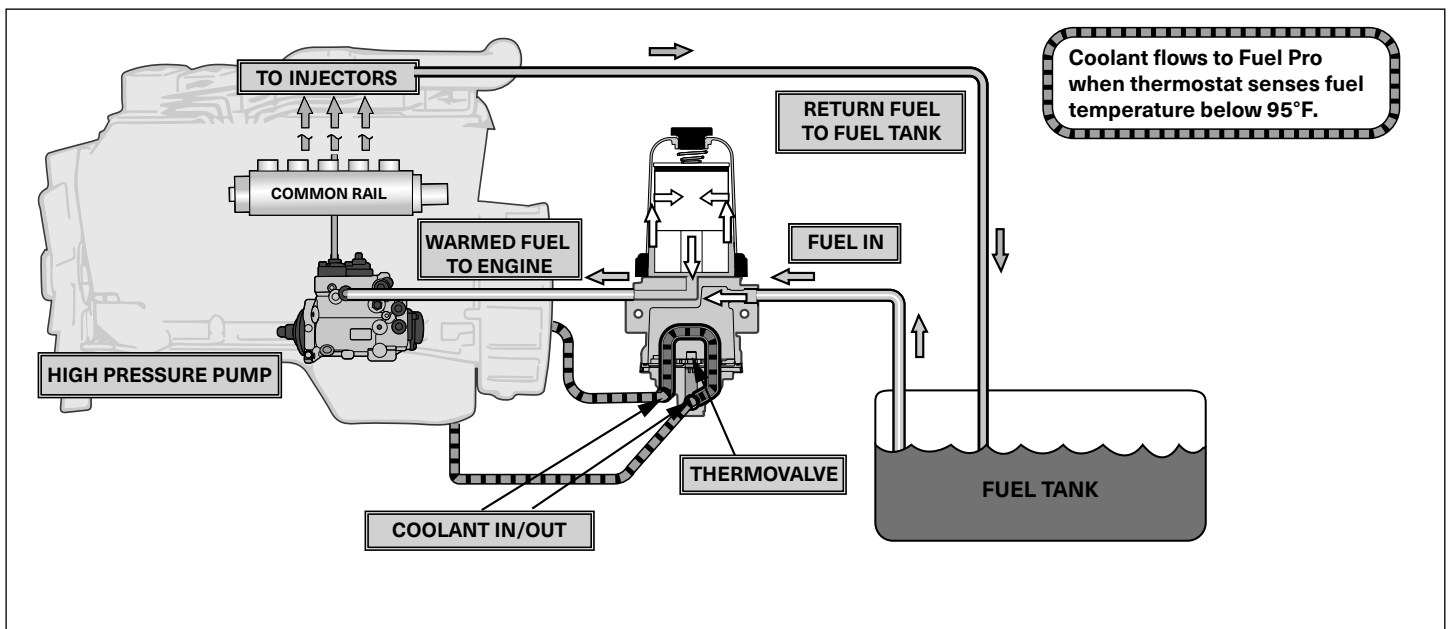

RETURN FUEL HEAT INSTALLATION

To upgrade from the unheated or coolant heat Fuel Pro 382 to return fuel heat, order the bottom plate upgrade kit, P/N 382029-30DAV. Refer to service parts description .

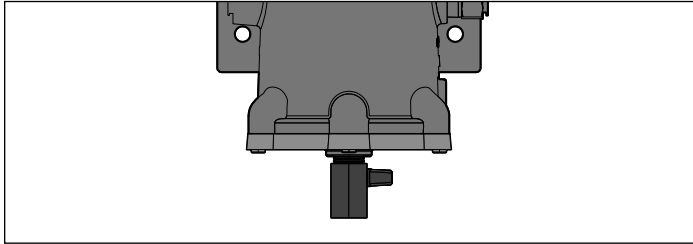

Flat Bottom Plate

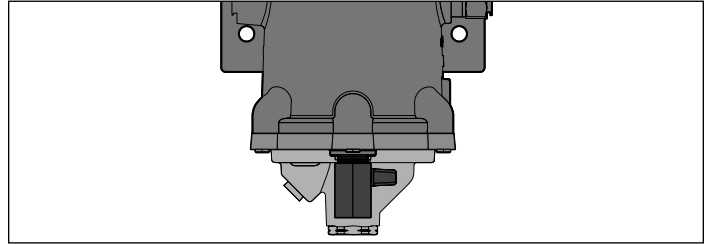

Coolant Heat or Return Fuel Heat Bottom Plate

Fuel System Diagram showing Return Fuel Heat Connections

For optimum heater performance locate the tee as close to the engine return connection as possible

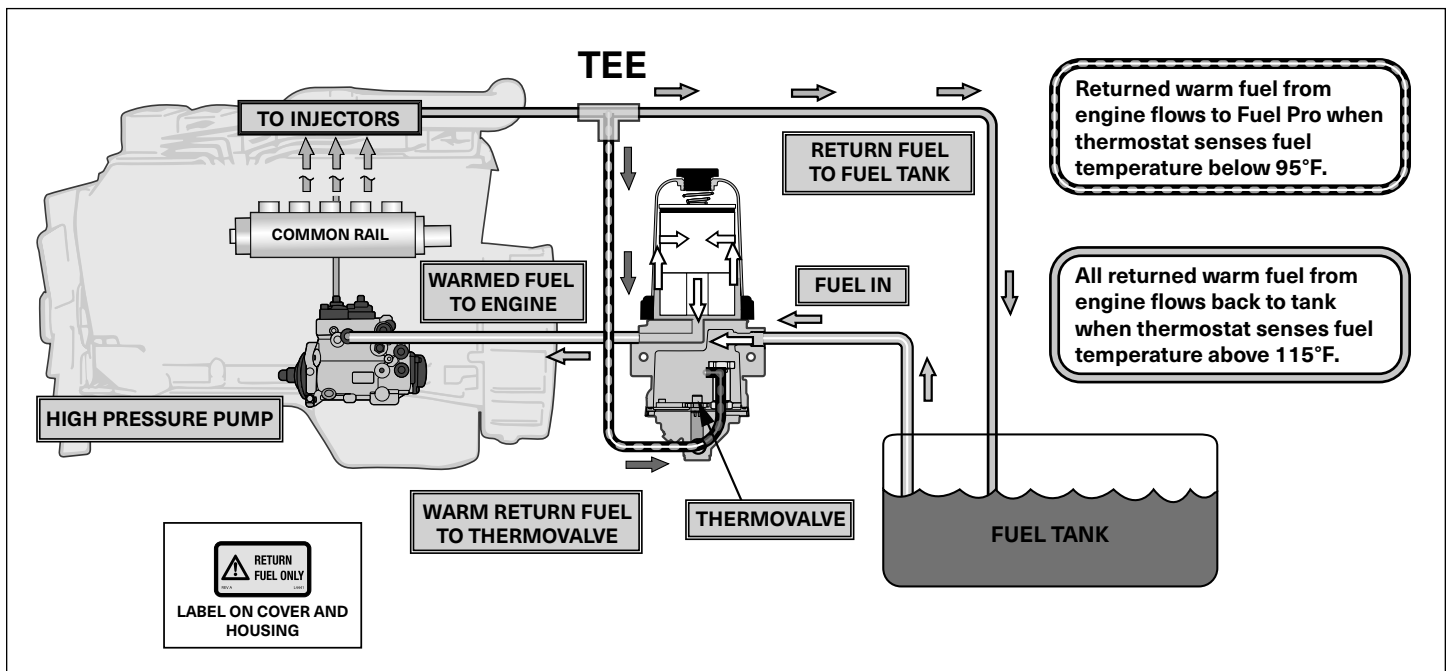

VISUAL DIAGNOSTICS-AIR VS. VAPOR BUBBLES

There are two kinds of bubbles that may be visible at the fuel pump inlet of a diesel fuel system. The bubbles can be characterized as either air bubbles or vapor bubbles.

Air Bubbles

Air bubbles are caused by any air leak on the vacuum (suction) side of the fuel system from the fuel tank pick-up to, and including the lift pump (see Figure 1).

If there is an air leak in the fuel system, air bubbles will be present in the clear cover of the Fuel Pro. Follow test procedures outlined in "Diagnostic Procedures for Air Leaks" (see page 13) for air leak diagnostics. If there are no bubbles present in the Fuel Pro cover and the engine continues to run rough, lopes or has a loss of power, there may be an air leak between the Fuel Pro outlet port and lift pump inlet. This type of air bubble can be seen if a sight tube is installed at the lift pump inlet. Air bubbles may also be visible in the fuel return (spill) hose out of the fuel gallery. These leaks are easily eliminated by checking and torquing the fuel fittings in the area of the leak.

TEST 1: A quick procedure to determine if the air leak is between the fuel tank and the Fuel Pro is to remove the Fuel Pro inlet hose and route a new hose from the Fuel Pro inlet into a container of fuel or the fuel tank fill cap opening. Start the engine and check for bubbles.

If there are no air leak symptoms, but bubbles are present in a sight tube at the fuel lift pump inlet, they are most likely vapor bubbles.

Vapor Bubbles

All diesel fuel has some level of entrained air caused by the natural splashing that occurs in the fuel tank during normal vehicle or equipment operation. Vapor bubbles develop in the Fuel Pro because the pressure inside the Fuel Pro is lower than the atmospheric pressure in the fuel tank. Vapor bubbles can vary from champagne size up to ¼" in diameter. They may increase in size or volume as engine RPM increases. The lower pressure draws the entrained air/vapor out of the fuel and these bubbles will be visible as the fuel exits the Fuel Pro (see Figure 2). As the fuel enters the lift pump, it is pressurized and the bubbles are compressed back into the fuel. There will be no bubbles on the fuel return side of the system. These vapor bubbles will not affect the performance of the engine.

TEST 2: An easy way to determine the difference between vapor and air bubbles is by temporarily removing the filter element from the Fuel Pro. Fill the cover with clean diesel fuel, replace the vent cap and re-run the outlet fitting sight glass test. If there are no bubbles visible in the sight glass, then the bubbles that were previously visible were vapor bubbles. If bubbles are still present then they are air. If air bubbles still exist, re-run the test in **TEST 1** to eliminate the chassis plumbing as a variable.

There is no troubleshooting or repair procedure required for vapor bubbles. Vapor bubbles do not cause performance issues and will not be present after the lift pump.

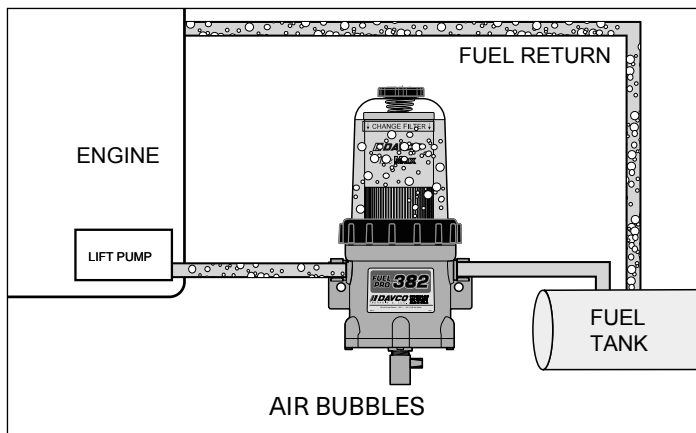

Figure 1

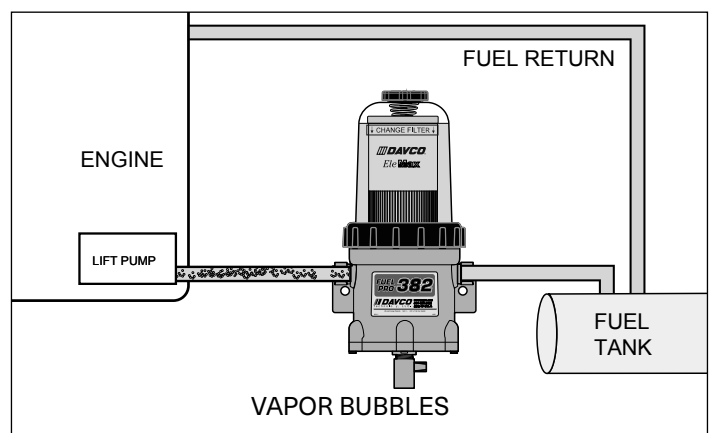

Figure 2

DIAGNOSTIC PROCEDURES FOR AIR LEAKS

Every Fuel Pro is factory tested for leaks and is identified with a traceable number prior to shipment. Most field issues associated with leaks are related to loose fittings. These leaks are easily eliminated by checking and torquing the fuel fittings in the area of the leak. Some fittings may also require the application of liquid or paste type thread sealant.

All suction side fuel filters experience bubbles. It is normal to see champagne size bubbles in the Fuel Pro cover, at the Fuel Pro outlet or at the lift pump.

IN ORDER TO RETURN A FUEL PRO FOR EVALUATION, THE FOLLOWING PROCEDURES/TESTS MUST BE COMPLETED BEFORE REQUESTING A DAVCO RGA (RETURN GOODS AUTHORIZATION) NUMBER.

- I. Air bubbles will be visible in the clear cover of the Fuel Pro if the leak originates between the fuel tank and the Fuel Pro. The following is a quick test to isolate the air leak source.
 - A. Remove the Fuel Pro inlet hose.
 1. Install a jumper hose from the Fuel Pro to the fuel tank (through the fill cap) or to a container of fuel.
 2. Start the engine. If this eliminates the air bubbles, the air source is at the fuel tank fittings or hose connections.
 3. Tighten all fittings and connectors. Retest.
 - a. If air bubbles persist, the air source is on the Fuel Pro side of the system:
 - i. Tighten all fittings on the Fuel Pro.
 - ii. Loosen the collar until it spins freely. Apply downward pressure on the top of the cover and rotate the collar until contact. Use a DAVCO wrench (if necessary) to tighten the collar three additional ribs.
 - b. If the drain valve is suspected, install a plug in place of the drain valve (for test purposes only).
4. If air bubbles persist, test as follows:
 - a. Remove the Fuel Pro from the chassis.
 - b. Plug the fuel outlet port. Do not remove filter, cover/collar, vent cap, drain valve and/or check valve. If the Fuel Pro is equipped with a pre-heater, do not remove the pre-heater.
 - c. Apply 15 PSI of air pressure at the fuel inlet. Immerse the Fuel Pro in a tank of water and look for air bubbles.
 - d. Correct the source of the air leak and retest.
- II. Bubbles Not Visible: If there are symptoms of sucking air (indicated by engine loping/rough running performance/power loss, etc.) and there are no bubbles in the clear cover, the air leak is either at the Fuel Pro outlet fitting, vent cap o-ring, the lift pump inlet connection, or the fuel hose/connections to the lift pump. Inspect and tighten fittings as needed.
- III. Excessive Restriction: If the fuel level is at the top of the filter, replace the fuel filter. The Fuel Pro will not cause excess system restriction if the fuel level is below the top of the filter. The only exception is if the grommet is not installed in the bottom of the filter element.
- IV. Loss of Prime: When air is introduced into the fuel system, (i.e. draining water from the Fuel Pro or when replacing the fuel filter) a check valve is needed to keep the fuel system primed from the Fuel Pro back to the fuel tank. A check valve is standard with every Fuel Pro.
- V. To test for proper check valve operation, place a drain pan under the Fuel Pro, remove the fuel inlet hose and open the vent cap. Fuel should not flow out of the Fuel Pro, although slight seepage of fuel is normal. If fuel flows out of the Fuel Pro fuel inlet, "Check Valve Service" (See page 19).

VISUAL DIAGNOSTICS WITH CLEAR COVER

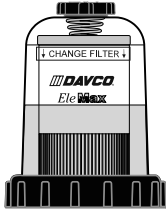
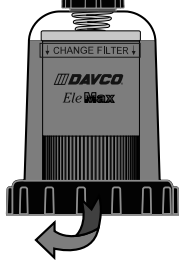
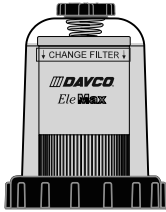
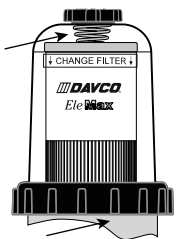
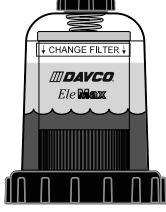
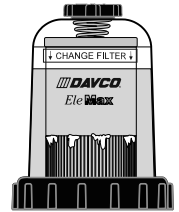
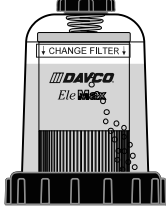
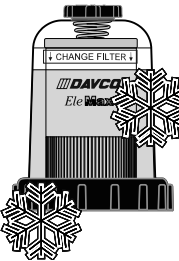
<p>Fuel level is not at the top of the fuel filter. → Normal-Do not change the filter.</p>		<p>Fuel drains back to the fuel tank when changing the fuel filter or draining separator. → Remove the check valve assembly. Clean or replace and retest. Check air leaks in the fuel system.</p>	
<p>Fuel level is at the top of the filter. Low power. → Change the filter at the first available opportunity.</p>		<p>There is a power complaint and the fuel level is below the collar. → Check for a missing grommet at the lower end of the filter or missing/broken spring at top of filter.</p>	
<p>Water is noticed in the cover. → Drain the water.</p>		<p>Fuel level is at the top of the filter and appears to be full of wax. → Change the filter. Run the engine for a minimum of 25 minutes at idle. Do not run at full RPM.</p>	
<p>Bubbles are seen flowing in with the fuel. → Check all fittings and lines from the fuel tank to the Fuel Pro. Check the cover and vent cap o-rings.</p>		<p>No engine coolant flow to the Fuel Pro. → Check for closed cutoff valves at the coolant lines to the Fuel Pro. Make sure the cab heater valve is open.</p>	

DIAGNOSTIC PROCEDURES FOR COOLANT OR RETURN FUEL HEAT THERMOVALVE

1. Remove the vent cap. Open the drain valve. Drain the Fuel Pro completely. Close the drain valve. The fuel can be reused after the installation.
2. Remove the fluid hoses going to the bottom plate. These will either be engine coolant hoses or return fuel hoses. Engine coolant hoses will have to be plugged when removing them from the Fuel Pro.
3. Remove the bottom plate.
4. While looking into the fluid port of the bottom plate, flow cold water over the thermovalve for 30 seconds, then run hot water over the thermovalve and determine if the thermovalve spool is opening and closing.
5. Replace with a new bottom plate seal and install the bottom plate onto the Fuel Pro.

There are two types of bottom plates with fluid heat; bolt-on and bottom collar.

- Torque the collar version to 50 to 60 ft-lb. Apply two or three drops of liquid or paste type thread sealant to secure the bottom collar). Use seal P/N 101994DAV.
 - Torque the bolts on the bolt-on version bottom plate to 10 ft-lb. Use seal P/N 910005DAV.
6. Reconnect the fluid hoses to the bottom of the Fuel Pro. Prime the Fuel Pro (see page 7) and check for leaks.

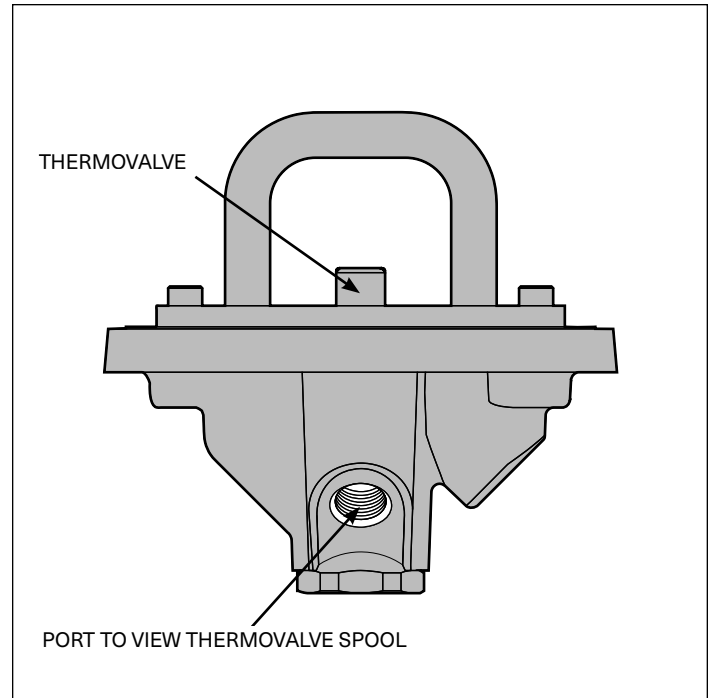
**RETURN FUEL HEAT DIAGNOSTICS**

During the initial installation or work on the fuel system you will see small bubbles in the clear cover until the engine is run for a period of time. This process could take up to 15

minutes of idling. If the bubbles persist diagnose the fuel system for leaks.

DIAGNOSTIC PROCEDURES FOR PRE-HEATER/OVERNIGHT HEATERS

Equipment Needed

- A precision low resistance ohm meter capable of measuring with accuracy to two decimal places.
 - Current flow meter (clamp-on type for DC current).
- ⚠ **DO NOT USE a test light that has a wire probe for any of these tests. If the wiring insulation is punctured, moisture and road salt can penetrate into the wires creating a corrosion issue and potential failure.**

CAUTION!

- ⚠ **Do not energize the pre-heater outside of the Fuel Pro. It can become very hot.**

12VDC/24VDC PTC Pre-heater Test Procedure

There are various configurations of pre-heaters available, including both 12VDC and 24VDC pre-heaters.

The voltage and wattage ratings are stamped on the hex of the pre-heater for identification purposes.

1. Disconnect the harness from the pre-heater.
2. Connect the ohm meter leads to the pins of the pre-heater. Use the following to determine whether the pre-heater resistance value is in the acceptable range.

PRE-HEATER	WATTS	RESISTANCE RANGE (OHMS)
12VDC	195W	0.4 to 0.6 @ 77°F (25°C)
24VDC	195W	2.0 to 3.0 @ 77°F (25°C)
12VDC	155W	0.95 to 1.2 @ 77°F (25°C)

120VAC Overnight Heater Test Procedure

1. Disconnect the cord from the overnight heater.
2. Connect the ohm meter leads to the pins of the overnight heater. Use the following to determine whether the overnight heater resistance value is in the acceptable range.

OVERNIGHT HEATER	WATTS	RESISTANCE RANGE (OHMS)
120VAC	75W	173 to 203 @ 77°F (25°C)

FILTER CHANGE PROCEDURE

Change the filter when the fuel reaches the top of the "CHANGE FILTER" lettering on the cover.

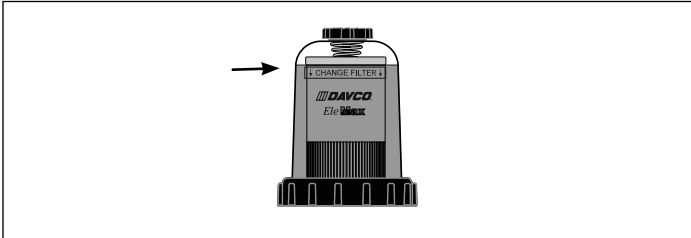

For filter selection visit www.davco.com for the correct filter for your application or call DAVCO Customer Service at 800-328-2611.

1. Remove the vent cap and open the drain valve to drain the fuel below the collar level. Close the drain valve.
2. Remove the collar using the DAVCO collar wrench (P/N 380134DAV). Remove the clear cover.
3. Remove the filter and seals. Dispose of the filter and the seals properly.
4. Using a clean shop rag, clean the cover, collar, vent cap and threads on the Fuel Pro body. Do not use harsh chemicals to clean the clear cover.
5. Install the new filter and seals.
6. Install the clear cover and collar.
7. Apply downward pressure on the top of the cover and rotate the collar until contact.
8. Use a DAVCO collar wrench (if necessary) to tighten the collar three additional ribs.

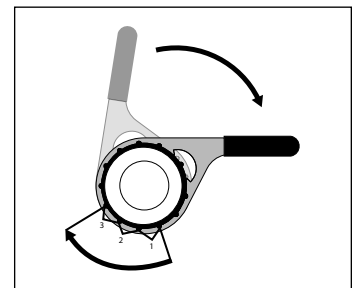
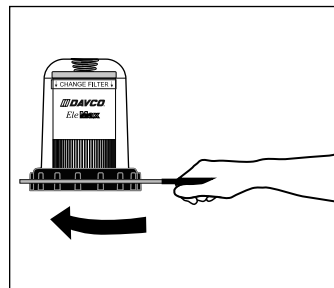
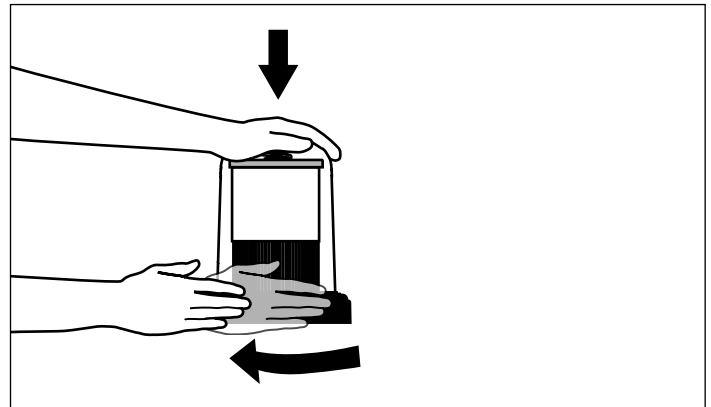

9. Prime the Fuel Pro (see page 7) and check for leaks.

It is normal for the fuel level to vary after the initial start-up and during engine operation. Filter performance is not affected.

Note: After a filter change it is **normal** to see slight foaming (tiny bubbles) in the clear cover for a period of time.

- The foaming fuel is the air introduced during the filter service process and will clear up as the engine runs and considered normal.
- The length of this process will vary based upon the fuel flow rate of the engine and length of fuel lines.

PREVENTATIVE MAINTENANCE

Environmental Concerns and Seasonal Maintenance

- Steam clean the Fuel Pro with fresh water regularly to keep corrosive salt or dirt from building up on the housing, cover, and collar.
- Extreme winter or salt corrosion environments may require lubrication of the collar with anti-seize lubricant every 180 days.

Weekly water drains

1. Turn off the engine and remove the vent cap.
2. Place a suitable container under the Fuel Pro and open the drain valve.
3. Collected water will flow into the container. When fuel begins to flow out the drain, close the drain valve. Drain the least amount of fuel as possible.
4. Install the vent cap and tighten it by hand until it clicks.
5. Start the engine and raise the RPM for one minute to purge the air from the system.

During each filter change

- Change the o-rings on the cover and vent cap (included with the service filter kit).

Annual inspection

- Inspect all electrical connections and housing for corrosion.
- Inspect all fuel fittings for leaks.
- Inspect the Fuel Pro for damage or signs of leaks.

CHECK VALVE SERVICE



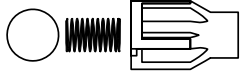
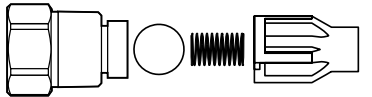
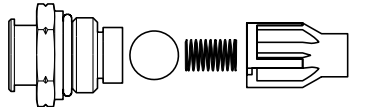
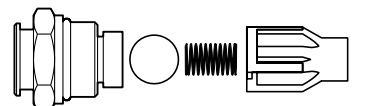

To test for proper check valve operation, place a drain pan under the Fuel Pro, remove the fuel inlet hose and open the vent cap. Fuel should not flow out of the Fuel Pro, although slight seepage of fuel is normal. If fuel flows out of the Fuel Pro fuel inlet:

1. Remove the vent cap. Open the drain valve. Drain the Fuel Pro completely. Close the drain valve. The fuel can be reused after the installation.
2. Use a back-up wrench to hold the check valve body and remove the fuel hose from the inlet of the Fuel Pro.
3. Remove and disassemble the check valve assembly.
4. Clean and inspect the check valve body. Replace the check valve body if any cuts, grooves or nicks are evident or if the ball seat is not smooth.
5. Inspect the check valve spring and spring retainer. If the spring or spring retainer is broken or if the check valve ball has grooves, nicks or is out of round, replace with a check valve service kit. Otherwise, clean and reassemble the check valve assembly. The spring retainer snaps into the groove in the check valve body.
6. Apply liquid or paste type thread sealant to the assembly. Install the check valve assembly into the body. Torque to 44-60 ft-lb.
7. Apply liquid or paste type thread sealant to the fuel inlet fitting and reconnect the fuel inlet hose.
8. Prime the Fuel Pro (see page 7) and check for leaks.

It is normal for the fuel level to vary after the initial start-up and during engine operation. Filter performance is not affected.

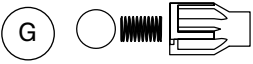
FUEL PRO CHECK VALVE SERVICE PART NUMBERS		
101132DAV	Check Valve Service Kit (Includes Ball, Spring, and Retainer)	
103071DAV	Check Valve Assembly (Includes Body and Check Valve Service Kit)	
103209PAC	Voss Check Valve Assembly (for PACCAR, 2017 and new only)	
103102DAV	Voss Check Valve Assembly (for Navistar)	

SERVICE PART NUMBERS

SERVICE PARTS AND KITS		
A	240023DAV	Vent Cap Service Kit (vent cap and o-ring)
B	103100DAV	Cover Service Kit (Collar, Spring, Vent Cap and Vent Cap O-ring - Collar o-ring not included)
C	103101DAV	Cover with Red Stripe and Black Band (Collar, Spring, Vent Cap and Vent Cap O-ring, Collar o-ring)
D	380056DAV	Filter Spring
E	102425DAV	Collar
F	380072DAV	O-Ring Service Kit (Vent Cap/Cover)
G	101132DAV	Check Valve Service Kit (Ball, Spring, and Retainer)
		
H	103071DAV	Check Valve Assembly (Body and Check Valve Service Kit)
		
H	103209PAC	Voss Check Valve Assembly (for PACCAR, 2017 and new only)
		
H	103102DAV	Voss Check Valve Assembly (for Navistar)
		
I	102008DAV	Drain Valve (Threads: ½"-14 NPT)
J	382027-28DAV	Combination Drain Kit (includes drain, dust cap and plug for use on units with cover with black band. Part number for unit contains an "E". Replaces ESOC fitting 102844, except on Freightliner Trucks.
K	382160NAV	Check Valve Assembly with Hex Cap for Return Fuel Heat (for Navistar)
L	382162DAV	Rebuild Kit: Includes: Cover Service Kit (Item B) Collar Seal Check Valve, Drain Valve, Bottom Plate Seal, Bottom Plate Bolts, and Instructions
<p>Pre-heater, Overnight Heater, Wrench, Bottom Plate, and Water in Fuel Sensor (WIF) information is on the following pages.</p>		

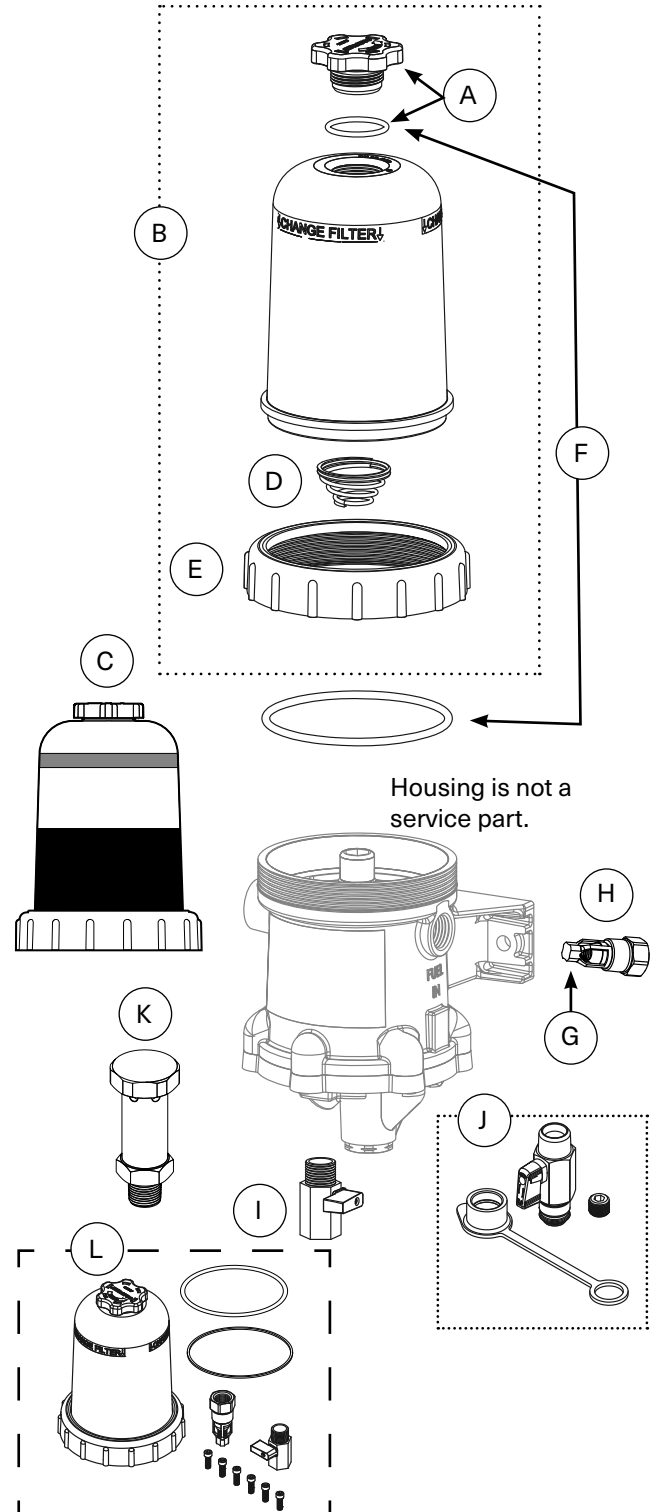

SERVICE PART NUMBERS

PRE-HEATER PARTS		
102220DAV	Pre-heater Chassis Harness, Weather Pack Connector, Wire Lengths 24" and 180"	
102376DAV	Pre-heater Chassis Harness, Metri-Pack Connector, Wire Lengths 24" and 180"	
102691DAV	Kit includes: 103529-12VDC 195W PTC Pre-heater, Weather Pack Connector, 1/2"-14 NPTF Threads, Harness Length 19.31", seals, plug, and clamp, Pre-heater Chassis Harness, Weather Pack Connector, Lengths 24" and 180"	
102692DAV	Kit includes: 24VDC 195W PTC Pre-heater, Weather Pack Connector, 1/2"-14 NPTF Threads, Harness Length 19.81" (103505 - terracotta color connector), seals, and plug	
102693DAV	Kit includes: 12VDC 195W PTC Pre-heater, Metri-Pack Connector, 1/2"-14 NPTF Threads, Harness Length 19.81", seals, and plug	
102694DAV	Kit includes: 12VDC 195W PTC Pre-heater, Weather Pack Connector, 1/2"-14 NPTF Threads, Harness Length 19.81", seals, and plug	
103528DAV	12VDC 195W PTC Pre-heater, Metri-Pack Connector, 1/2"-14 NPTF Threads, Harness Length 19.81"	
103529DAV	12VDC 195W PTC Pre-heater, Weather Pack Connector, 1/2"-14 NPTF Threads, Harness Length 19.81"	
103594DAV	12VDC 155W PTC Pre-heater, Metri-Pack Connector, 1/2"-14 NPTF Threads, Harness Length 24.50"	





*Note: Visit www.davco.com, Form F1263 for 12VDC and 24VDC Pre-heater Parts for pre-heaters installed prior to 2007. For Specific OEM numbers for pre-heaters, contact customer support at 1-800-328-2611.

SERVICE PART NUMBERS

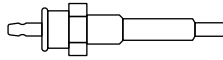

OVERNIGHT HEATER PARTS		
101868DAV	120VAC Overnight Heater Straight Cord, Cord length: 72"	
102015DAV	120VAC Overnight Heater "Y" Cord, Cord lengths: 84" and 120"	
102145DAV	120VAC 75W Overnight Heater, 1/2"-14 NPTF Threads	

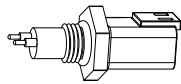
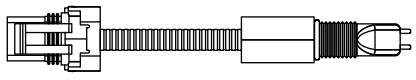
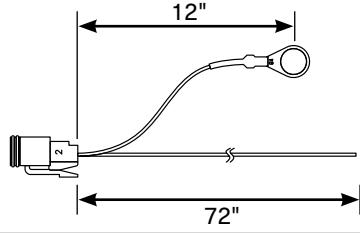
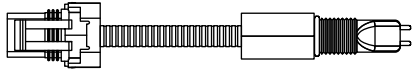
COLLAR WRENCHES		
P/N 382002DAV	P/N 380134DAV	P/N 382152DAV
Composite Wrench	Metal Wrench	Heavy Duty Wrench, 3/8" thick. Use with a 3/8" socket wrench drive.

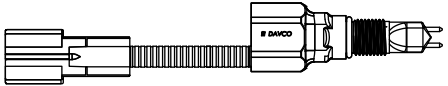
SERVICE PART NUMBERS

WATER-IN-FUEL (WIF) SENSOR PARTS		
101017PAC	One Pin WIF, 1/8"-27 NPTF Thread	
102512DAV	Two Pin WIF, Deutsch Connector (gray), 1/2"-20 UNF Threads, Harness Length 3.36"	
102521DAV	Two Pin WIF, Deutsch Connector (black), 1/2"-20 UNF Threads, Harness Length 3.36"	
102507DAV	Two Pin WIF, M14-2 Threads with Seal, Deutsch Connector (Fleetguard and Bus Applications)	
102519DAV	Two Pin WIF, Metri-Pack Connector, 1/2"-20 UNF Threads, Harness 17.5" (Freightliner)	
102600DAV	Two Pin WIF Wiring Harness (Used with 102512DAV and 102521DAV) Deutsch Connector, Wire Lengths 12" and 72"	
102770DAV	Two Pin WIF, Metri-Pack Connector, 1/2"-20 UNF Threads, Harness Length 6.50" (Freightliner)	
103111DAV	Two Pin WIF, Tyco/AMP Connector, 1/2"-20 UNF Threads, Harness Length 3.25" (Paccar)	
103445DAV	Two Pin Digital WIF, AMP Connector, 1/2"-20 UNF Threads, Harness Length 7.25" (Navistar, replaces 102871DAV)	

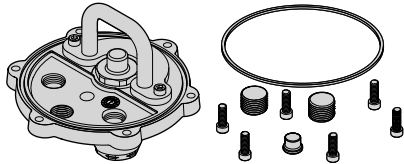
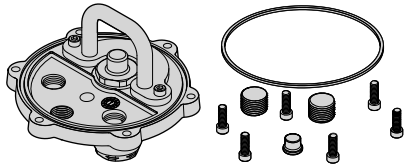
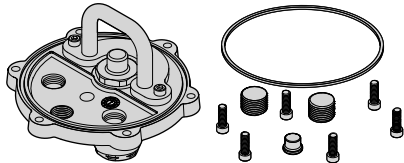
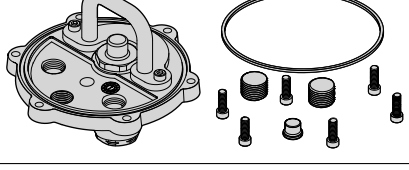
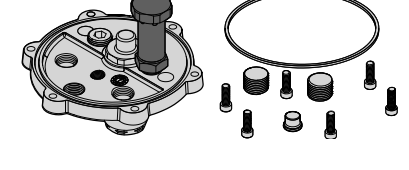
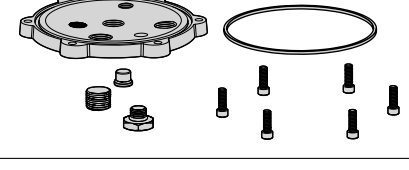
SERVICE PART NUMBERS

BOTTOM PLATES FOR FLUID HEAT		
382029-23DAV	"Universal" (All Ports are machined.) Coolant Heat Ports (2), Threads: 3/8"-18 NPTF Pre-heater Ports (2), Threads: 1/2"-14 NPTF, plugs supplied WIF Port, Threads: 1/2"-20 UNF, plug supplied Drain Port, Threads: 1/2"-14 NPT (drain valve not supplied) 6 bolts, 1 square cut seal	
382029SVCB	Coolant Heat Ports (2), Threads: 3/8"-18 NPTF Pre-heater Ports (2), Threads: 1/2"-14 NPTF, plugs supplied Drain Port, Threads: 1/2"-14 NPT (drain valve not supplied) 6 bolts, 1 square cut seal	
382029-5SDAV	Coolant Heat Ports (2), Threads: 3/8"-18 NPTF WIF Port, Threads: 1/2"-20 UNF, plugs supplied Drain Port, Threads: 1/2"-14 NPT (drain valve not supplied) 6 bolts, 1 square cut seal	
382029NAV	(Navistar Bottom Plate) Coolant Heat Ports, (2) Threads: 9/16"-18 UNF Pre-heater Ports (2), Threads: 1/2"-14 NPTF, plugs supplied WIF Port, Threads: 1/2"-20 UNF, plug supplied Drain Port, Threads: 1/2"-14 NPT (drain valve not supplied) 6 bolts, 1 square cut seal	
382029-30DAV *Return fuel port: 3/8"-18 UNF	(Return Fuel Heat Bottom Plate) Drain port: 1/2"-14 NPTF (Drain valve not included) WIF Port, Threads: 1/2"-20 UNF, plug supplied	
382029-30NAV *Return fuel port: 9/16"-18 UNF for Navistar	Pre-heater Ports (2), Threads: 1/2"-14 NPTF, plugs supplied Overnight Heater Ports: Threads: 1/2"-14 NPTF, plugs supplied 6 bolts, 1 square cut seal	
BOTTOM PLATE (BOLT-ON) FOR FUEL PRO 382 WITHOUT FLUID HEAT		
382027-28DAV	Pre-heater Ports (2), Threads: 1/2"-14 NPTF, plugs supplied WIF Port, Threads: 1/2"-20 UNF, plug supplied, WIF Port, Threads: M14, plug supplied, Drain Port, Threads: 1/2"-14 NPT (Drain valve not supplied) 6 bolts, 1 square cut seal	
BOTTOM PLATE SEALS		
101994DAV	Seal, round, bottom collar	
910005DAV	Seal, square cut, bolt on	



A Clariance Technologies Company

WARRANTY POLICY

Please review DAVCO's Product Warranty terms and conditions carefully before installing and/or using a DAVCO product.

Diesel Pro® 243 and 245, Fuel Pro® 382, 482, 483, 485, 487 and 488, Industrial Pro®, Pro-Chek®, Sea Pro®

DAVCO Technology, LLC warrants these products to be free of defects in material and workmanship for five years, 500,000 miles or 10,000 hours (whichever comes first) and electrical parts for two-years, 200,000 miles or 4,000 hours (whichever comes first) from the purchase date*.

Shop Pro®

DAVCO Technology, LLC warrants the Shop Pro (except for the motor) to be free of defects in material and workmanship for two years from the date of purchase. The Shop Pro motor is warranted for one year from date of purchase.

REN Products, EyeMax®, and Fuel Pro® 384

DAVCO Technology, LLC warrants these products to be free of defects in material and workmanship for two-years or 200,000 miles (whichever comes first) from the purchase date.

By installing and/or using the product, you agree to be bound by the following:

This Warranty does not apply to:

- Failure or inadequate performance due to improper installation, misuse, misapplication, faulty installation, alteration/modification, poor maintenance, neglect, accident, or conditions resulting from actions outside DAVCO's control, including but not limited to the use of contaminated, corrosive, and unapproved fluids.
- Downtime, loss of use, loss of profits or income, loss of capital, cost of substitute equipment, living expenses, claims by purchaser's customers or other third parties, or other incidental, special or consequential damages.
- Attachments, accessory items, and parts not manufactured or distributed by DAVCO.
- Any aftermarket or OEM component not approved specifically to work with a DAVCO manufactured product
- Product that has been installed with aftermarket parts or altered or modified in any way.
- Normal wear and tear, abuse, vandalism, acts of God, improper storage or handling, disasters such as flood, fire, or war, failure to operate, maintain or repair in accordance with instructions, or failure to repair the vehicle into which the product is installed in accordance with the vehicle manufacturer's instructions or common maintenance practices.

This warranty is the sole warranty made by DAVCO. DAVCO makes no other warranties, expressed or implied, of merchantability or fitness for a particular purpose.

In the unlikely event of a defective product, DAVCO will either rework the defective product or replace it at DAVCO's discretion. If you feel you have a warrantable issue, contact DAVCO at 800-328-2611 for a Return Goods Authorization (RGA) number **. An RGA number is required prior to the return of any product.

* Purchase Date: The date of the first retail purchase of a new vehicle or piece of equipment from the OEM dealer or factory. For "Over the Counter" purchase: The date of sale to the first retail customer.

**Products submitted for Warranty consideration will be inspected by DAVCO personnel. Re-work or replacement will be based on DAVCO's Warranty procedure and/or the results of their evaluation. DAVCO's Warranty Program does not in any way constitute a product guarantee.



A Clarience Technologies Company

PARTS RETURN GENERAL POLICY

A Return Goods Authorization (RGA) must be obtained from DAVCO prior to returning any products. Returns may be accepted under the following circumstances:

- **Order Shipping Error:** A credit against the original invoice, including freight charges for both ways will be issued for returns in which DAVCO inadvertently shipped incorrect quantity or product.
- **Overstock:** Returns for ordering more product(s) than required, or incorrect part(s), will be accepted within 60 days from the date of purchase. Proof of purchase will be required, i.e.: original invoice/delivery receipt. These types of return(s) are subject to a minimum restock fee of 40% or \$40.00, whichever is higher. Additional restock fees may apply. Product(s) will be inspected for "like new" condition and additional costs will be the responsibility of the customer. No obsolete parts may be returned.
- **Freight charges for return(s) will be the responsibility of the customer.**