

# FUEL PRO<sup>®</sup> 485

## PRODUCT DATA SHEET

**DAVCO FUEL PRO 485** is an all-in-one fuel filter, water separator, and fuel pre-heater for heavy duty on-highway diesel engines with flow rates up to 180 gallons per hour.

The Fuel Pro 485, with an optional pre-heater, overnight heater and water-in-fuel sensor will keep the engine running in any weather conditions.

Three layer filter design, with filtration to 10 microns, provides enhanced water separation capabilities for ultra-low sulfur diesel fuel with low interfacial tension.

### Applications

- Detroit DD13, DD15, DD16
- Cummins X15
- New Cascadia

### Models and Options

- Base Model - Unheated
- Electric Heat
  - 12VDC or 24VDC Pre-heater
  - 120VAC Overnight heater
- Water-In-Fuel (WIF) sensor

### Typical Installation

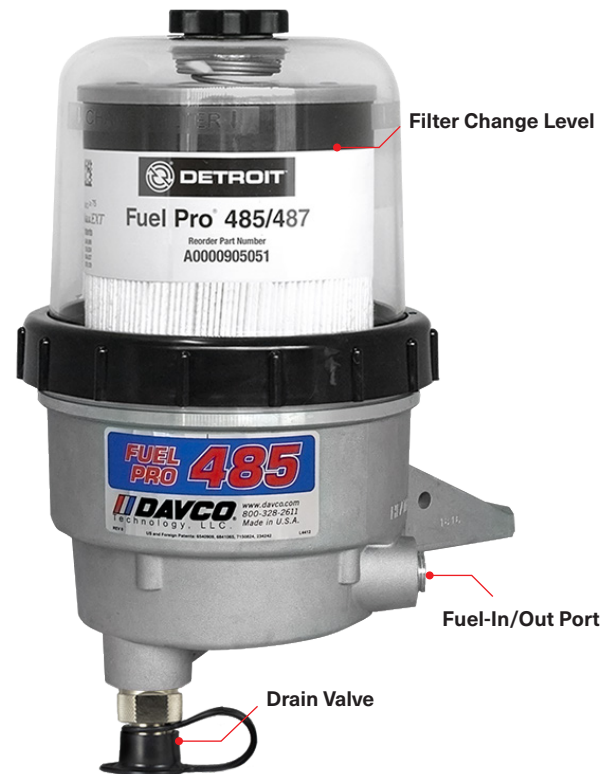
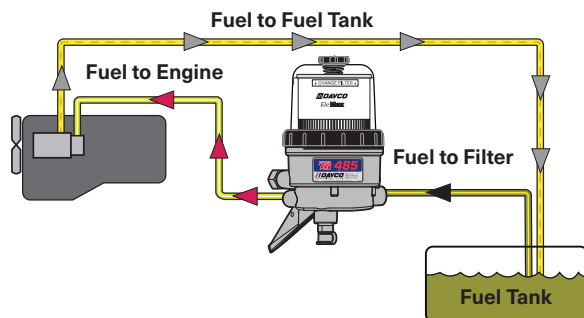

### Filter Technology

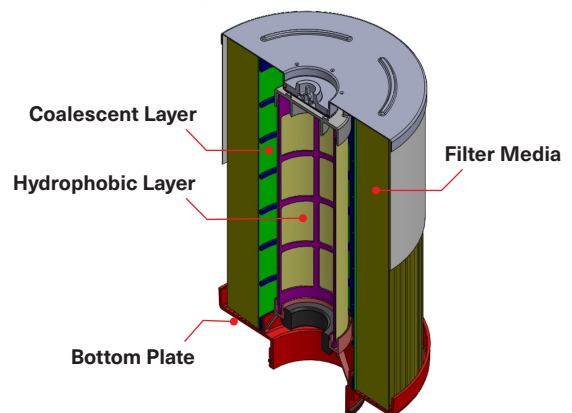

A **Clariance Technologies** Company

**DAVCO Technology, LLC**

1600 Woodland Drive, Saline, MI 48176-1629

800-328-2611

customerservice@davco.com

www.davco.com

# FUEL PRO® 485

## Specifications

Height, Overall, Unheated Model	15.54 in. (394.8 mm)
Depth, Overall	10.34 in. (262.63 mm)
Width, Maximum	11.62 in. (295.14 mm)
Weight, Dry	Approx. 11 lbs
Minimum Service Height	5.5 in. (139.7 mm)
Max Fuel Flow	180 gph
Pre-heater	12VDC (155W or 195W) or 24VDC (195W)
Overnight heater	120VAC, 75W, .65A

## Filtration Performance (10 micron at 174 GPH)

Micron	10
Coarse water removal (%)	>99%
Emulsified water removal (%)	>93%
% Emulsified water removal (end of life filter)	>80%
Dirt holding capacity (grams)	150

## Port Interface

Fuel In	M22 x 15-6H
Fuel Out	M22 x 15-6H

## Dimensions

Dimensions are in inches [millimeters]

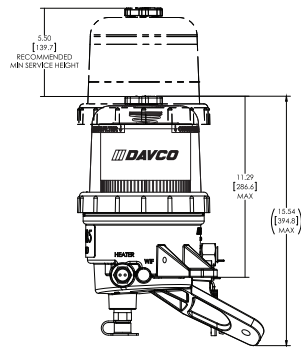

LEFT

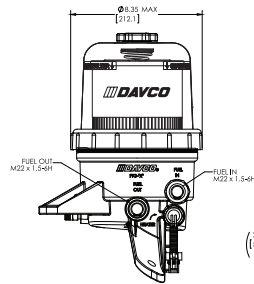

FRONT

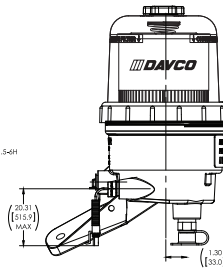

RIGHT

Mounting Hole Distance: 3.963 [99.9]  
Mounting Hole Openings: .531 [13.05]

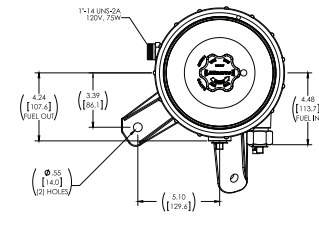

TOP

## Sales Codes

### New Cascadia

Sales Codes	DAVCO P/N	Description
122-1J3	<b>485150FTL-10</b>	Fuel Pro 485
122-1J4	<b>485152FTL-10</b>	Fuel Pro 485 w/12V Pre Heater
122-1J5	<b>485162FTL-10</b>	Fuel Pro 485 w/12V Pre Heater and 120V Overnight Heater
122-1J6	<b>485150FTLE-10</b>	Fuel Pro 485 w/Black Band, Red Stripe Cover
122-1J7	<b>485152FTLE-10</b>	Fuel Pro 485 w/ 12V Pre Heater and Black Band, Red Stripe Cover
122-1J8	<b>485162FTLE-10</b>	Fuel Pro 485 w/12V Pre Heater, 120V Overnight Heater and Black Band, Red Stripe Cover

### New Cascadia with Cummins Engine

Sales Codes	DAVCO P/N	Description
122-1J9	<b>486151FTL-10</b>	Fuel Pro 486 w/ Water-In-Fuel Sensor (WIF)
122-1K0	<b>486153FTL-10</b>	Fuel Pro 486 w/12V Pre Heater and Water-In-Fuel Sensor (WIF)
122-1K1	<b>486163FTL-10</b>	Fuel Pro 486 w/12V Pre Heater, 120V Overnight heater, and Water-In-Fuel Sensor (WIF)

Replacement Filter:

Fleetguard Part Number: FS20083

Detroit Diesel Part Number: A0000905051

## DAVCO Technology, LLC

1600 Woodland Drive, Saline, MI 48176-1629

800-328-2611

customerservice@davco.com

www.davco.com

F3518 REV D

Updated on 4/26/2024