

FUEL PRO[®] 487

PRODUCT DATA SHEET

DAVCO FUEL PRO 487 is an all-in-one fuel filter, water separator, and fuel pre-heater for heavy duty on-highway diesel engines with flow rates up to 180 gallons per hour.

The Fuel Pro 487, with an optional pre-heater, overnight heater and water-in-fuel sensor will keep the engine running in any weather conditions.

Three layer filter design, with filtration to 10 microns, provides enhanced water separation capabilities for ultra-low sulfur diesel fuel with low interfacial tension.

Applications

- Detroit DD13, DD15, DD16
- All Freightliner/Western Star Chassis except Cascadia NGC

Models and Options

- Base Model - Unheated
- Electric Heat
 - 12VDC or 24VDC Pre-heater
 - 120VAC Overnight heater
- Water-In-Fuel (WIF) sensor, (standard when used with Cummins X15 Engines)

Typical Installation

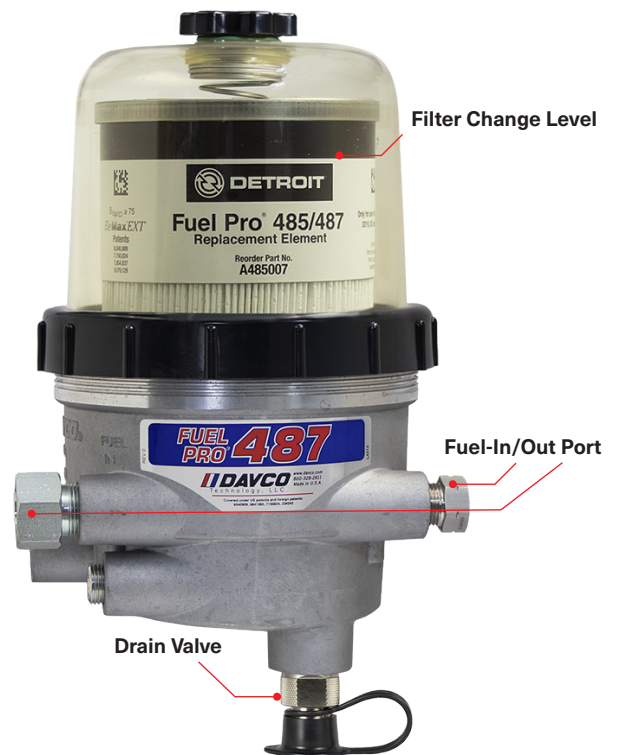
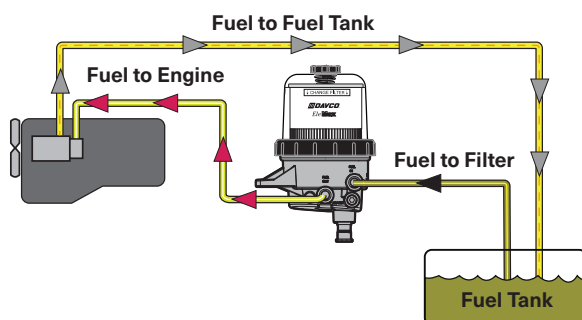

Filter Technology

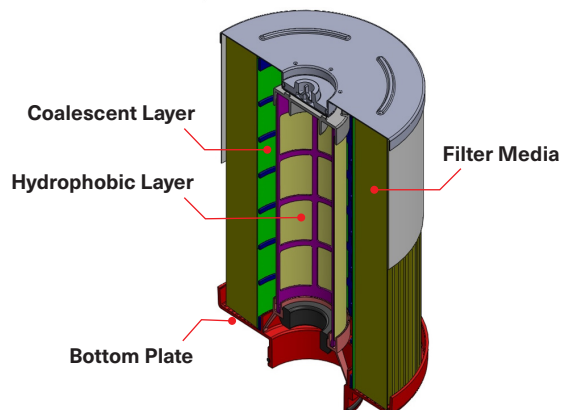

A Clariance Technologies Company

DAVCO Technology, LLC

1600 Woodland Drive, Saline, MI 48176-1629

800-328-2611

customerservice@davco.com

www.davco.com

FUEL PRO® 487

Specifications

Height, Overall, Unheated Model	14.68 in. (372.87 mm)
Depth, Overall	9.92 in. (252 mm)
Width, Maximum	8.35 in. (212.1 mm)
Weight, Dry	Approx. 11 lbs
Minimum Service Height	4 in. (101.6 mm)
Max Fuel Flow	180 gph
Pre-heater	12VDC (155W or 195W) or 24VDC (195W)
Overnight heater	120VAC, 75W, .65A

Filtration Performance (10 micron at 174 GPH)

Micron	10
Coarse water removal (%)	>99%
Emulsified water removal (%)	>93%
% Emulsified water removal (end of life filter)	>80%
Dirt holding capacity (grams)	150

Port Interface

Fuel In	½"-14 NPTF
Fuel Out	½"-14 NPTF

Dimensions

Dimensions are in inches [millimeters]

Mounting Hole Distance: 3.963 [99.9]
Mounting Hole Openings: .531 [13.05]

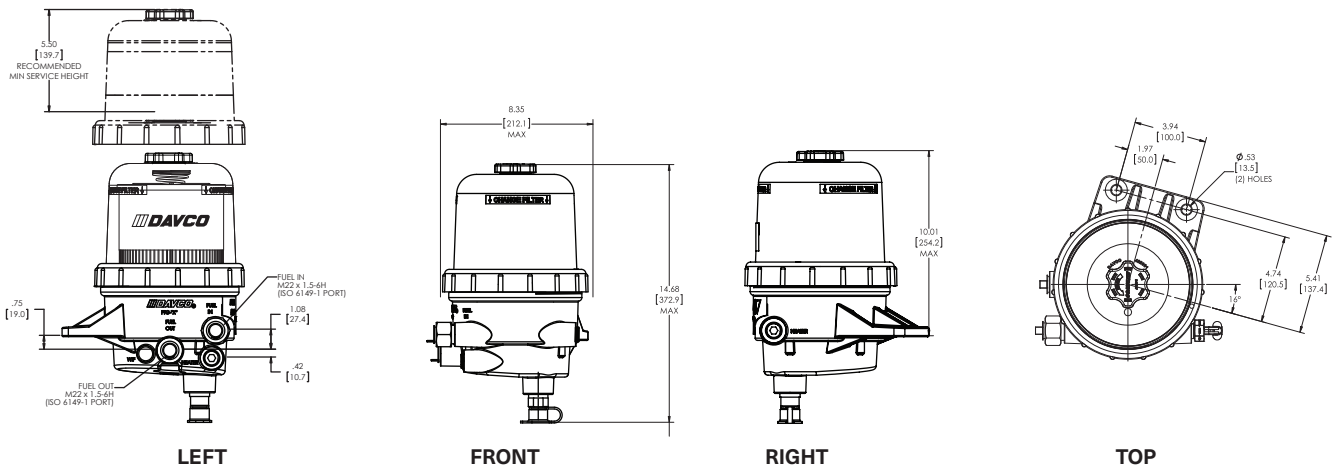

Sales Codes

Sales Code	DAVCO P/N	Description
122-1K3	487950FTL-08	Fuel Pro 487
122-1K4	487952FTL-08	Fuel Pro 487 with 195W 12VDC Pre-heater
122-1K5	487962FTL-08	Fuel Pro 487 with 195W 12VDC Pre-heater and 120VAC Overnight heater
122-1K6	487950FTLE-08	Fuel Pro 487 with Black Band, Red Stripe Cover
122-1K7	487952FTLE-08	Fuel Pro 487 with 195W 12VDC Pre-heater and Black Band, Red Stripe Cover
122-1K8	487962FTLE-08	Fuel Pro 487 with 195W 12VDC Pre-heater, 120VAC Overnight heater, and Black Band, Red Stripe Cover

Replacement Filter:
Fleetguard Part Number: FS20083
Detroit Diesel Part Number: A000090501

DAVCO Technology, LLC

1600 Woodland Drive, Saline, MI 48176-1629
800-328-2611 customerservice@davco.com www.davco.com

F3519 REV C
Updated on 4/26/2024