

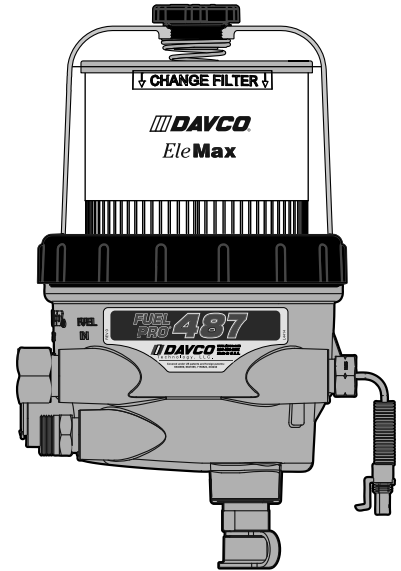

A Clarience Technologies Company

TABLE OF CONTENTS

Applications, Models, and Options..... 1
How it Works 1
SEEING IS BELIEVING® 2
Dimensions and Specifications..... 3
Δ Important Safety Precautions 4
Installation Instructions 5
120VAC Overnight Heater Installation..... 6
Water-in-Fuel Sensor (WIF) Installation 6
12VDC and 24VDC Pre-heater Installation 7
Fuel Pro 487 Installation Instructions 8
12VDC Pre-heater Wiring Instructions 13
Visual Diagnostics - Air vs. Vapor Bubbles..... 17
Visual Diagnostics with Clear Cover 18
Diagnostic Procedures - Air Leaks 19
Diagnostic Procedures - Check Valve and Heater Testing 20
Filter Change Procedure 21
Preventative Maintenance 22
Service Procedures - Bypass Valve..... 23
Service Part Numbers..... 24
Warranty Policy 26
Parts Return Policy 27



FOR UPDATED INFORMATION VISIT WWW.DAVCO.COM

FUEL PRO 487
TECHNICAL MANUAL FOR DTNA

APPLICATIONS, MODELS, AND OPTIONS

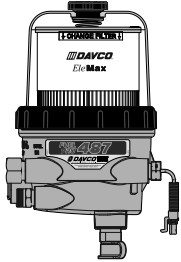

Applications

- Engine models
 - Detroit DD13, DD15, DD16
- All Freightliner/Western Star Chassis except Cascadia NGC

Meets/Exceeds engine manufacturer's stringent water separation requirements

Models and Options

- Base Model - Unheated Electric
- Pre-heater Options
 - 12VDC (155W or 195W) or 24VDC (195W)
 - 120VAC Overnight heater
- Water-in-Fuel (WIF) Sensor (standard when used with Cummins X15 Engines)

HOW IT WORKS

Fuel from the tank enters the Fuel Processor body (suction side of the fuel system).

Large contaminants and "free" water are separated from the fuel and remain in the body.

Fuel rises into the clear cover.

Contaminants and emulsified water are captured by the filter media.

Fuel level rises to maintain a fuel path through the clean filter media and with lowest restriction.

Clean, water-free fuel exits the Fuel Processor and flows to the engine fuel module.

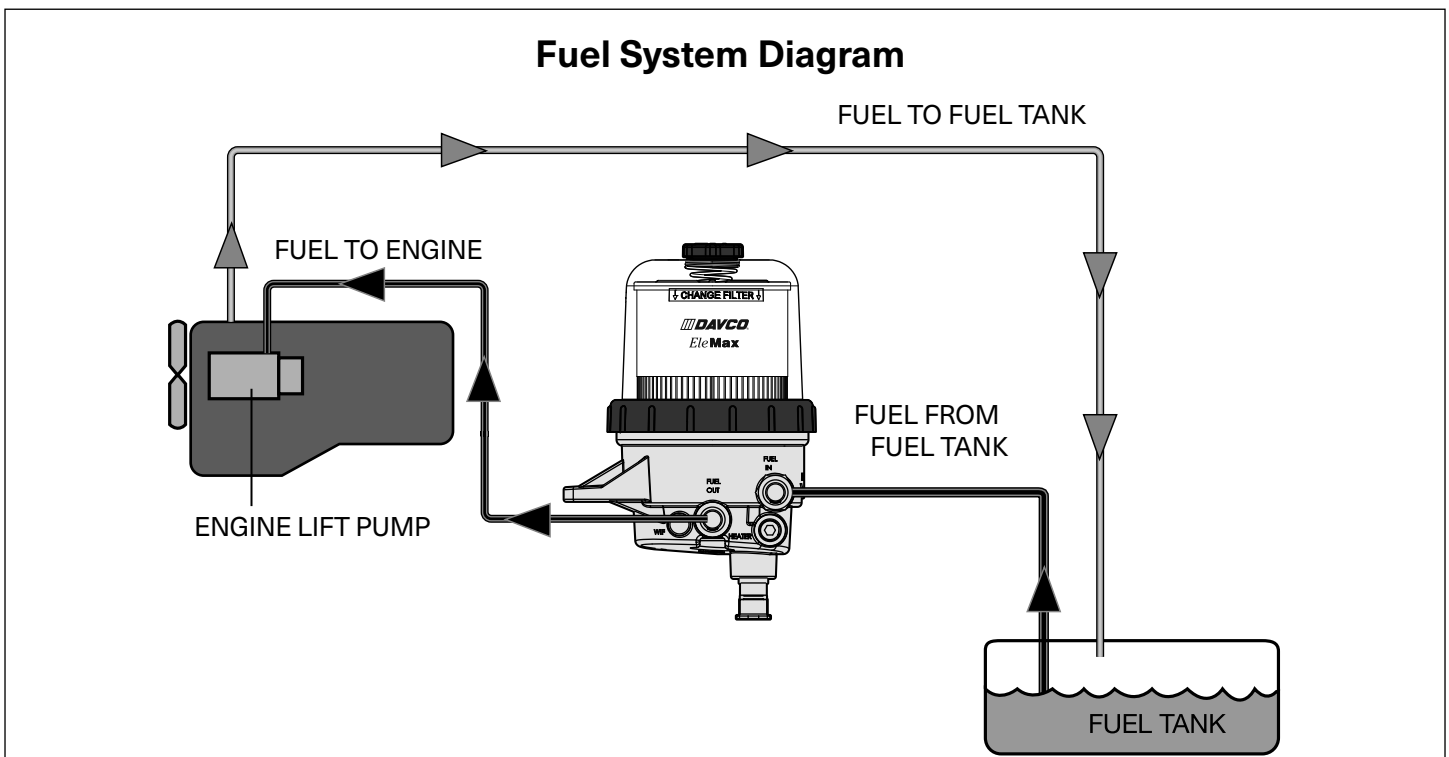

SEEING IS BELIEVING®

See when NOT to change the fuel filter.

See the condition of the fuel. Seeing what collects on the filter media or what’s happening inside the clear cover can help diagnose many fuel and mechanical conditions.

“Filter on Top” configuration. Water and debris removed from the fuel falls to the lower chamber and stays away from the filter media resulting in longer filter life.

Built in protection when priming the fuel filter. Unfiltered fuel is kept on the “dirty” side of the filter media during priming ensuring only clean fuel reaches the engine.

Patented media. The “Best in Class” StrataPore® media removes 98% of free and emulsified water. This far exceeds the performance of cellulose media.

<p>When new, the fuel level in the filter will be very low with minimal restriction. As the filter is used, contaminants collect on the filter from the bottom up. Fuel rises on the filter indicating remaining filter life.</p>	<p>Fuel level increases in clear cover. As contaminants collect on the filter, the fuel rises to a non-contaminated section of the filter, providing optimal filtration while maintaining lowest restriction.</p>
<p>Fuel level at filter wrap level. Even though the fuel level is now more than half of the filter element, the fuel is still flowing through clean media at minimal restriction levels. The filter still has significant life remaining.</p>	<p>The filter element is now completely covered by fuel. At this point, all of the media’s surface area is utilized. Restriction is increasing and the filter element should be changed at the next scheduled maintenance interval.</p>

DIMENSIONS AND SPECIFICATIONS

All dimensions are in inches (millimeters)

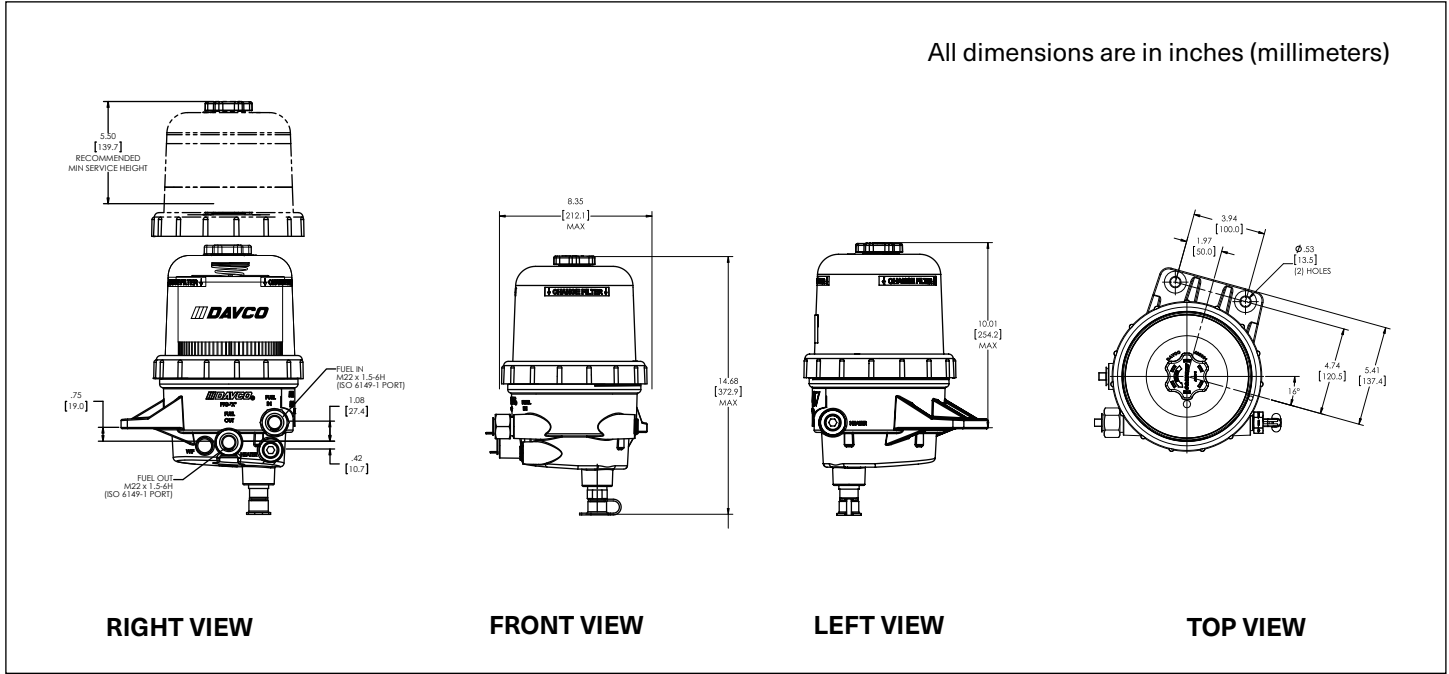

SPECIFICATIONS	
Height Overall	14.68 in.
Depth Overall	9.92 in.
Width, Max.	8.6 in.
Fuel In Connection	M22 x 15-6H
Fuel Out Connection	M22 x 15-6H
Filter Service Clearance Min.	5.5 in.
Max. Fuel Flow	180 gph
Pre-heater	12VDC (155W or 195W) or 24VDC (195W)
Overnight heater	120VAC, 75 W, .65 A

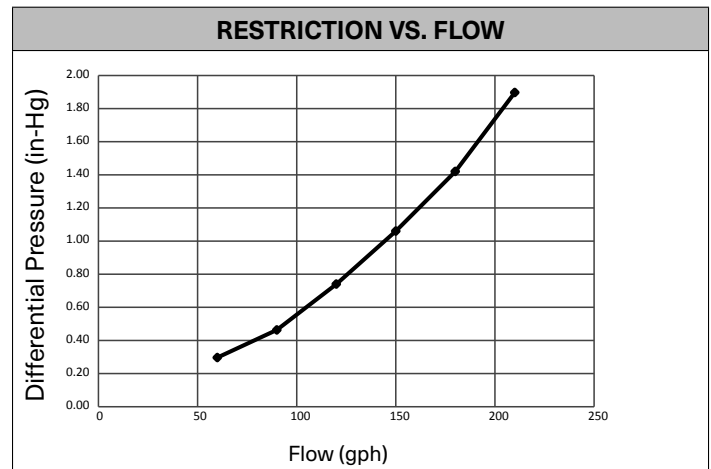

FILTRATION PERFORMANCE AT 174 GPH	
Micron	8
Coarse water removal (%)	>99%
Emulsified water removal (%)	>93%
% Emulsified water removal (end of life filter)	>80%
Dirt holding capacity (grams)	150

⚠ IMPORTANT SAFETY PRECAUTIONS

General Safety Precautions

- **FOR USE WITH DIESEL FUEL ONLY**
- To avoid serious injury or death, follow the safety information in this document.
- Keep this manual. If you need to replace the manual, call customer service at 800-328-2611 or visit www.davco.com/documents.htm for a replacement.
- Read all product safety labels.
- Refer to appropriate regulations for environmental and workplace safety rules.

WARNING: To prevent personal injury

- **Scalding hazard:** When diesel fuel is circulated through an operating engine, it can become very hot. Do not allow fuel to come in contact with eyes or unprotected skin. Allow the engine and fuel to cool to ambient temperature before replacing the fuel filter or performing service operations which could result in spillage of fuel from the fuel system.
- **Fire Prevention:** Heated fuel can form combustible vapor mixtures in the area around the fuel source. To eliminate the potential for fire, keep open flames, sparks or other potential ignition sources away from the work area. Do not smoke during filter replacement or service operations.
- **Inhalation Precaution:** Always perform engine or vehicle fuel system maintenance in a well ventilated area that is kept free of bystanders.
- The ignition key must be in the **off** position, unless otherwise directed. To avoid unintentional engine startup, use a lockout key and/or signage to alert personnel that work is being performed.
- Do not energize pre-heater outside of the Fuel Pro. Caution! Very hot.

Government Regulations

- Engine fluids (oil, fuel, and coolant) may be a hazard to human health and the environment. Handle all fluids and other contaminated materials (such as filters and rags) in accordance with applicable regulations. Recycle or dispose of engine fluids, filters, and other contaminated materials according to applicable regulations.

INSTALLATION INSTRUCTIONS

Installation Location

The Fuel Pro must be installed between the fuel tank and the fuel transfer pump. In some cases, the Fuel Pro can be used as the only fuel filter in the system. This is generally dependent on the engine model year. Consult the engine manufacturer for their recommendation.

Mounting the Fuel Pro

- Do not install the Fuel Pro directly on the engine.
- Mount vertically with the cover and element pointing up.
- Make sure there is enough top and side clearance for the cover to be conveniently removed for filter replacement.
- The Fuel Pro MUST be installed so that the filter element is above the "FULL" level of the fuel tank.

⚠ The ignition key must be in the off position, unless otherwise directed. To avoid unintentional engine startup, use a lockout key and/or signage to alert personnel that work is being performed. Chock the wheels.

1. With the engine shut down and at ambient temperature, close the fuel shutoff valve (if equipped) and place a suitable container under the fuel filters.
2. Remove the primary fuel filter element assembly, sedimentor, and/or water separator. Drain the used element and dispose of it in an environmentally responsible manner, according to state and/or federal (EPA) recommendations.

Fuel Line Routing

To minimize fuel system restriction, observe the following guidelines when plumbing the fuel system:

- Keep the fuel line routing as smooth as possible with no low-hanging loops which can trap water.
- Use 90° elbows only when necessary.
- If the fuel hoses are cut to length on the job, be sure that the inner liner of the fuel hose is not cut by the fitting, which can cause check valve performance issues. Make sure hoses are clean and free of debris before installing.
- To avoid damaging the aluminum Fuel Pro body, do not over-tighten fuel lines or fuel line fittings.

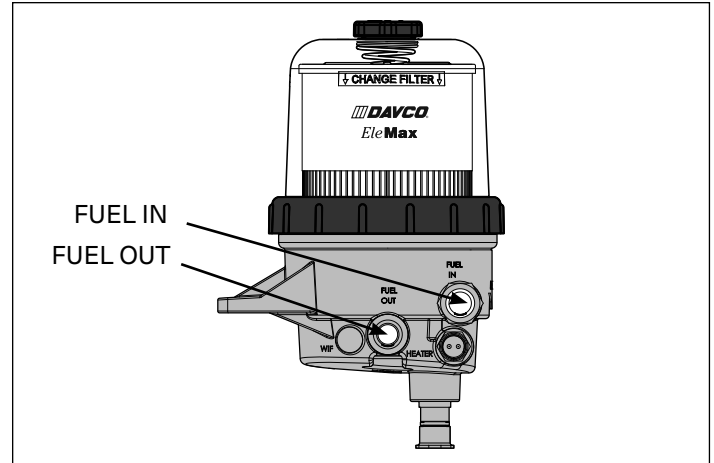

1. Route the fuel supply line from the pick up on the fuel tank to the Fuel Pro inlet (labeled "FUEL IN" on figure below, not labeled on housing).
2. Route the fuel outlet line from the Fuel Pro outlet (labeled "FUEL OUT") to the inlet of the fuel pump.

Priming the Fuel System

1. Check to make sure the drain valve at the base of the Fuel Pro is closed.
2. Remove the vent cap from the top of the clear cover. Fill the Fuel Pro full with clean fuel. Re-install the vent cap. Tighten the vent cap by hand until it clicks.
3. Start the engine. When the lubrication system reaches its normal operating pressure, increase engine RPM to high idle for one to two minutes. After the air is purged loosen the vent cap until the fuel level drops to just above the collar. Tighten the vent cap by hand until it clicks.
4. Apply downward pressure on the top of the cover and rotate the collar until contact.
5. Use a DAVCO wrench if necessary to tighten 3 additional ribs.

The clear filter cover will not fill completely during engine operation. It will gradually fill over time and the fuel level will rise as the filter becomes contaminated.

120VAC OVERNIGHT HEATER INSTALLATION

The Fuel Pro 120VAC overnight heater is installed in the 120VAC heater port on the side of the Fuel Processor.

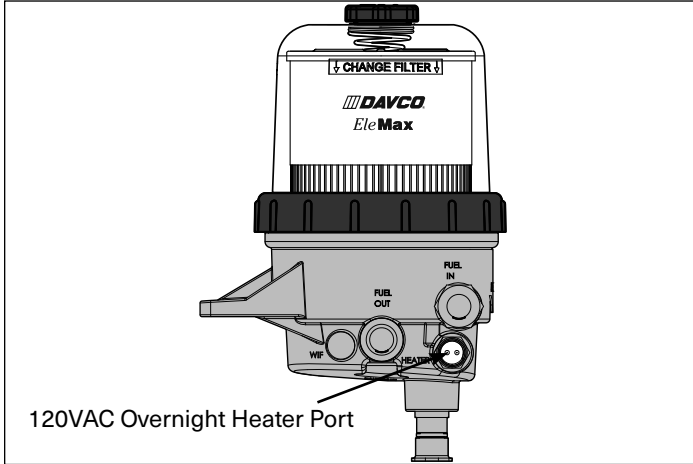

1. Open the vent cap. Open the drain valve by turning one to one and a half revolutions. Drain the Fuel Pro completely. Close the drain valve.
2. Remove the pipe plug from the heater port.
3. Apply liquid thread sealant to the heater threads and install into the 120VAC overnight heater port on the Fuel Pro. Tighten to 15-30 ft-lbs.
4. Connect the wire harness to the heater and route the harness to a location where it can easily be plugged into a 120VAC outlet.
5. Prime the Fuel Pro and check for leaks.

WATER-IN-FUEL SENSOR (WIF) INSTALLATION

1. Open the vent cap. Open the drain valve by turning one to one and a half revolutions. Drain the Fuel Pro completely. Close the drain valve.
2. Install WIF into WIF port. Torque to 20-24 in-lbs.
3. Install the filter and prime the unit.

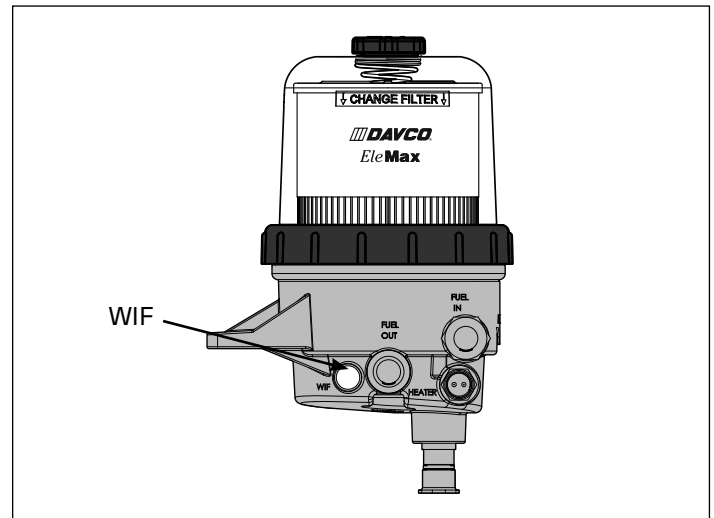

12VDC AND 24VDC PRE-HEATER INSTALLATION

The 12VDC or 24VDC Pre-heater is installed in the pre-heater port on the side of the Fuel Pro.

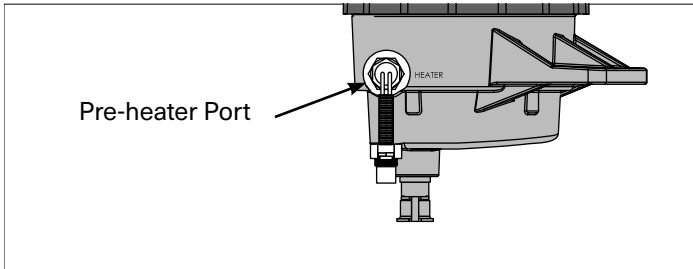

1. Open the vent cap. Open the drain valve by turning one to one and a half revolutions. Drain the Fuel Pro completely. Close the drain valve.
2. Remove the pipe plug in the heater port.
3. Apply liquid thread sealant to the pre-heater threads and install into the port. Tighten to 15-30 ft-lbs.
4. Connect the chassis harness to the Fuel Pro harness.
5. Connect the power lead to the fused accessory side of the ignition switch. The fuse rating depends on the pre-heater installed.
6. Prime the Fuel Pro and check for leaks.

Approved fuse ratings

- 12VDC System:
 - 20 amp fuse for a 155W PTC heater
 - 25 amp fuse for a 195W PTC heater
- 24VDC System:
 - 15 amp fuse for a 195W PTC heater

If the keyed circuit will not handle the required amperage for the pre-heater, use a relay.

Refer to "12VDC Pre-heater Wiring Instructions" ("12VDC Pre-heater Wiring Instructions" on page 13 for pre-heater wiring.

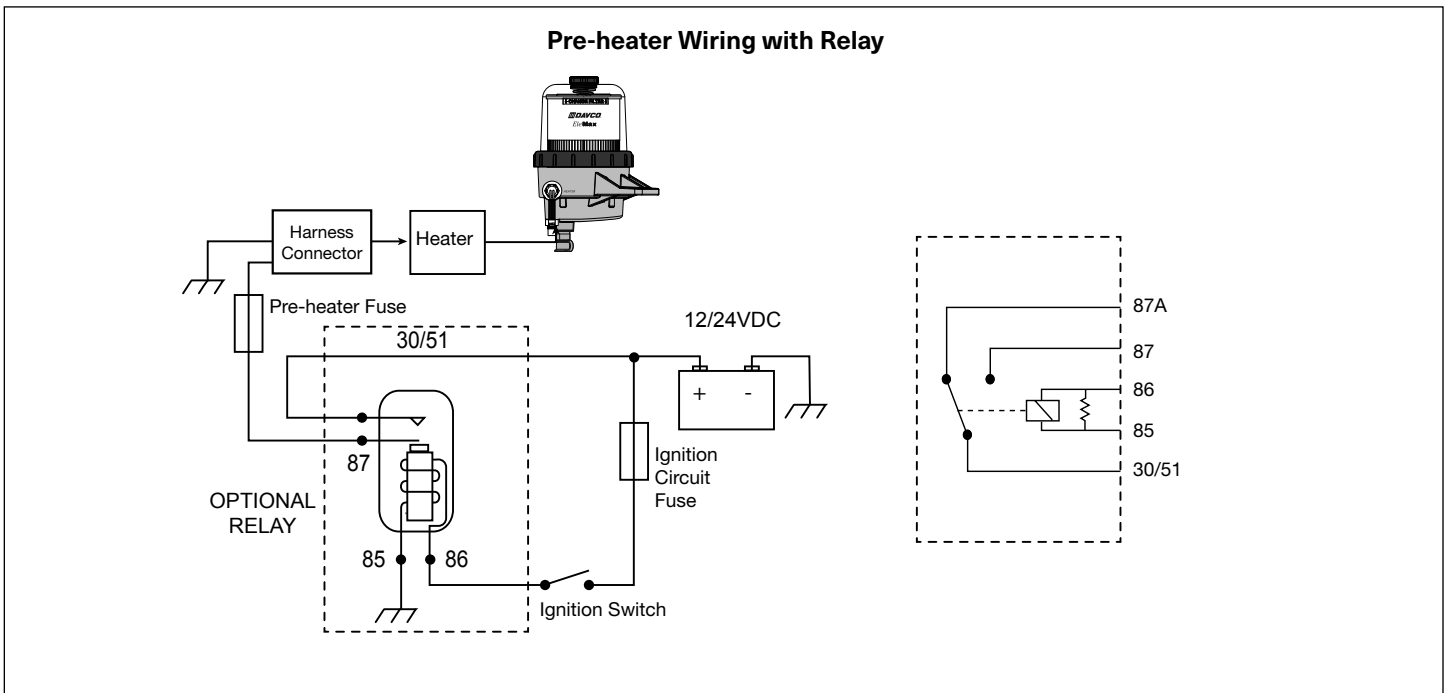

FUEL PRO 487 INSTALLATION INSTRUCTIONS

Step 1

Install the fuel INLET and OUTLET fittings into the Fuel Pro 487 facing upward at a 45° angle towards the back of the unit.

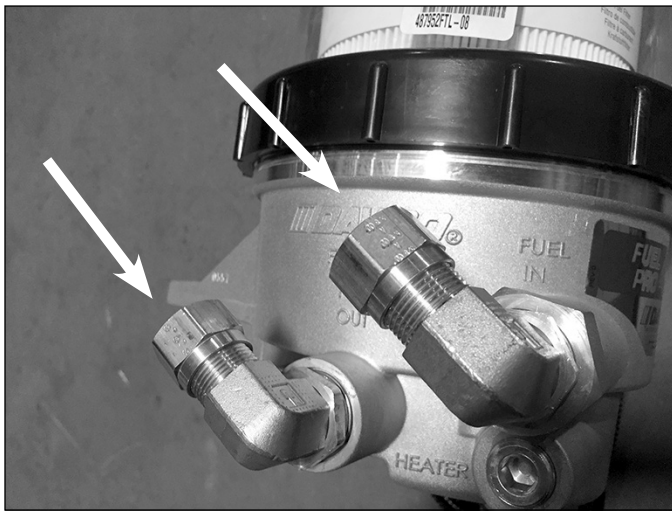

Step 2

Locate the two holes on the driver side bumper support bracket just forward of the steering box.
Note: There will **not** be a steering box in models that include rack and pinion steering.

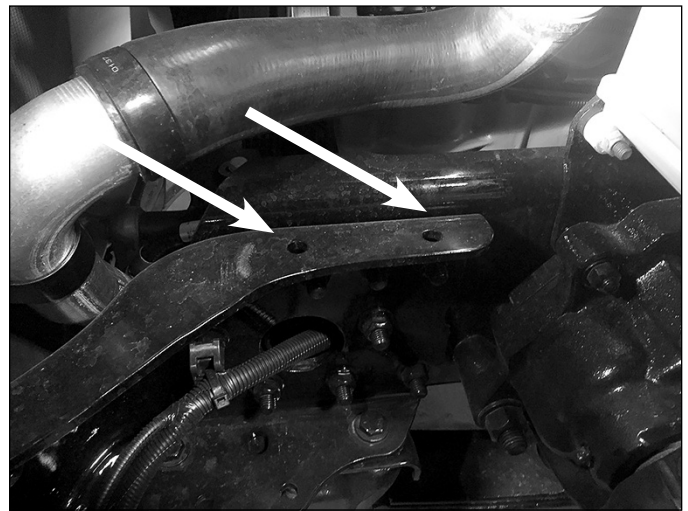

Step 3

Attach the Fuel Pro 487 to the front most hole using a ½" bolt, washer and lock nut (for hand clearance). Rotate the unit inward and attach the Fuel Pro 487 to the rear hole using a ½" bolt, washer and lock nut. Torque both bolts to 96 ft-lb.

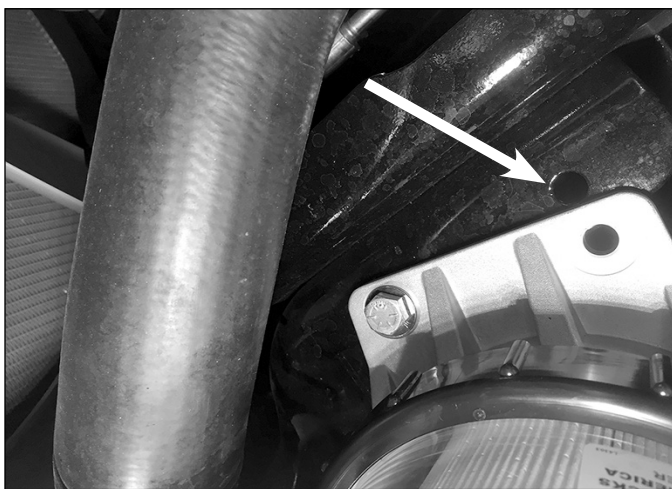

Step 4

Disconnect the fuel supply line at the filter module and remove the zip ties.

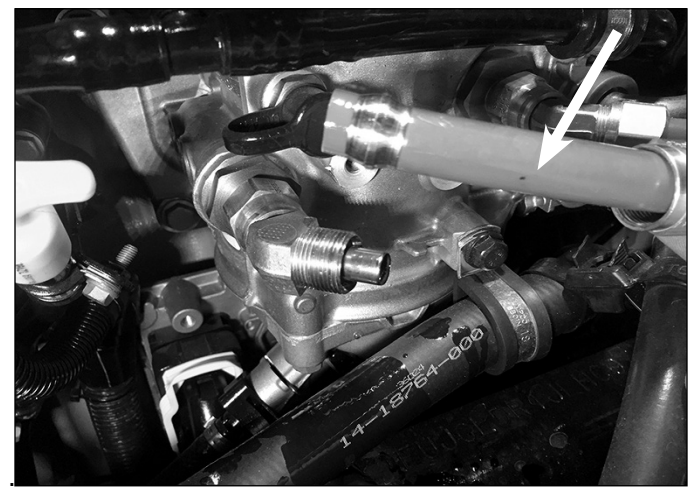

FUEL PRO 487 INSTALLATION INSTRUCTIONS

Step 5

Rotate the fuel module inlet fitting towards the front of the truck and tighten.

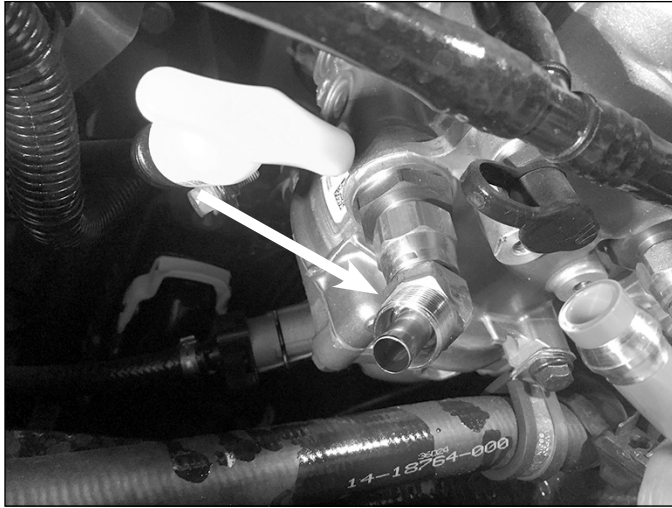

Step 6

Install and route a new piece of 5/8" fuel tube toward the front of the truck coming from the fuel module inlet fitting.



Step 7

Route the new 5/8" fuel line coming from the inlet on the engine fuel module to the outlet of the Fuel Pro 487. Cut and connect.

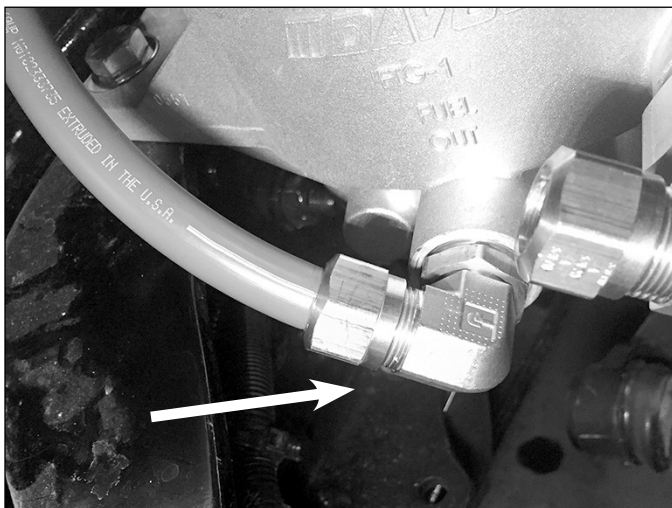

Step 8

Install a 5/8" union on the fuel supply line and attach a new piece of fuel tubing to the compression fitting.



FUEL PRO 487 INSTALLATION INSTRUCTIONS

Step 9

Route the new 5/8" fuel line coming from the fuel tank supply and to the Fuel Pro 487 inlet on the Fuel Pro 487, then cut and connect.

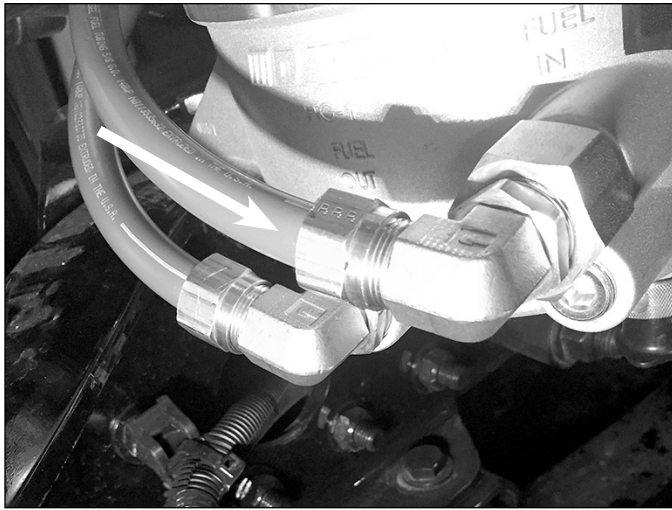

Step 10

Remove the top mounting bolt on the power steering reservoir as shown.



Step 11

Install the supplied cushion (or P) clamp around the fuel tubing and replace the top steering reservoir bolt.

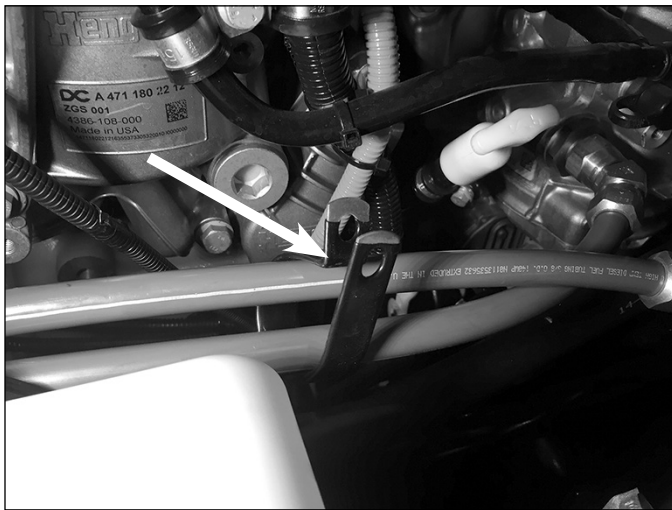

Step 12

Zip tie the fuel supply hoses as needed.

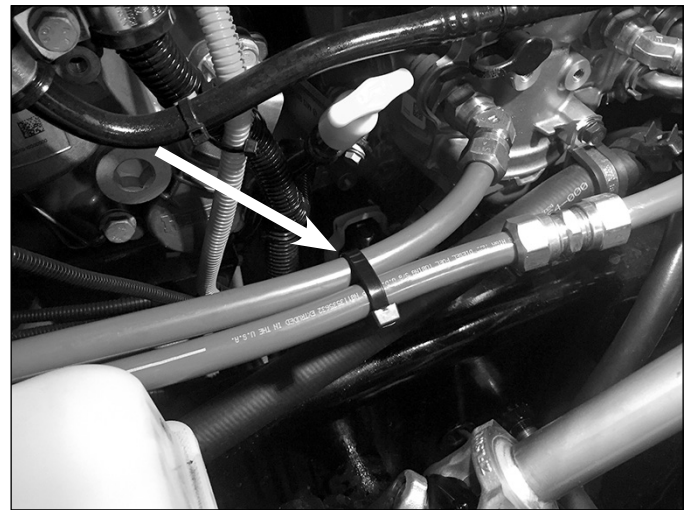

FUEL PRO 487 INSTALLATION INSTRUCTIONS

Step 13

Remove the vent cap from the Fuel Pro 487.

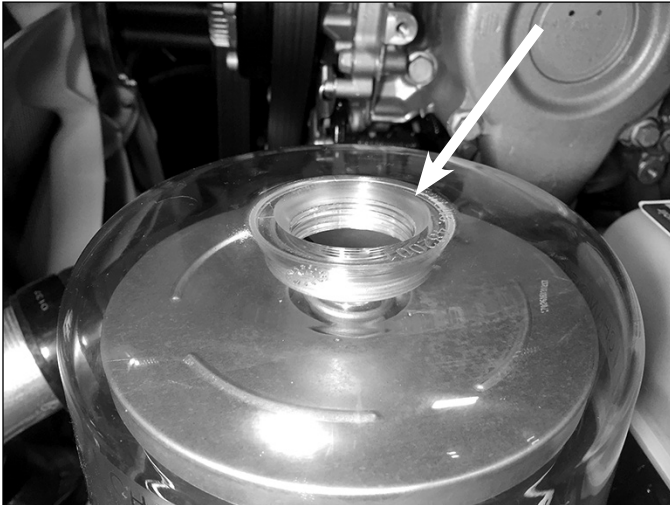

Step 14

Prime the Fuel Pro 487 by pouring fresh diesel fuel into the clear cover to fill to the top of the filter.



Step 15

Cycle the hand primer pump on the fuel module.



Step 16

Stop when the fuel level drops to just above the collar on the Fuel Pro 487. Repeat steps 14 through 16 twice to purge the air introduced from installing new fuel lines.



FUEL PRO 487 INSTALLATION INSTRUCTIONS

Step 17

Top off the Fuel Pro 487 cover and install the vent cap (tighten until it clicks).

Step 18

1. Start the engine and run for one minute.
 2. While the engine is running, slowly open the vent cap and allow the fuel to drop to approximately one inch above the collar.
 3. Tighten the vent cap by hand until it clicks. It is normal for the fuel level to vary after the initial start-up and during engine operation. Filter performance is not affected.
 4. Check the fuel system for any leaks.
- Fuel Pro 487 installation is complete.



12VDC PRE-HEATER WIRING INSTRUCTIONS

If installing 12VDC pre-heaters, coat the thread with a light coat of pipe sealant and torque to 15 to 30 Ft Lbs.

Step 1

Locate the 12VDC pre-heater and connect it to the chassis harness.

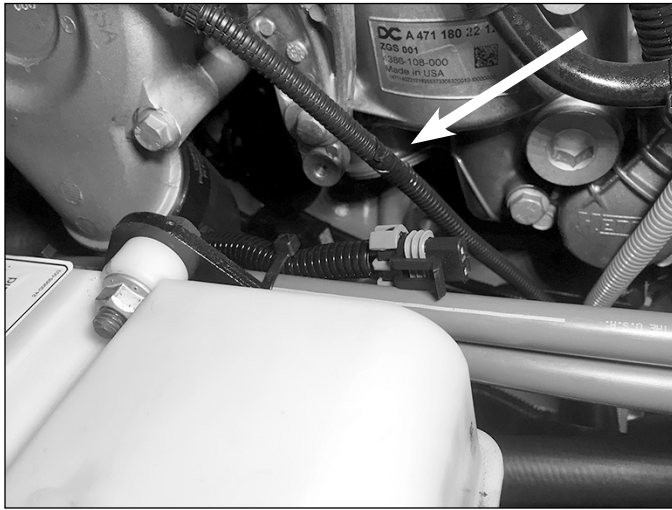

Step 2

Route the chassis harness around the power steering reservoir toward the firewall.



Step 3

Connect the ground eyelet from the chassis harness to the ground buss bar and zip tie as needed.

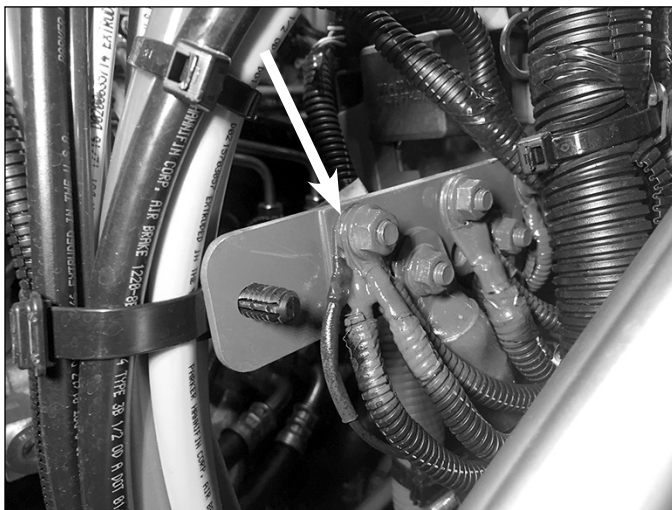

Step 4

Route the 12 volt power lead towards the SAM Chassis Connector. (Zip tie harness as needed).

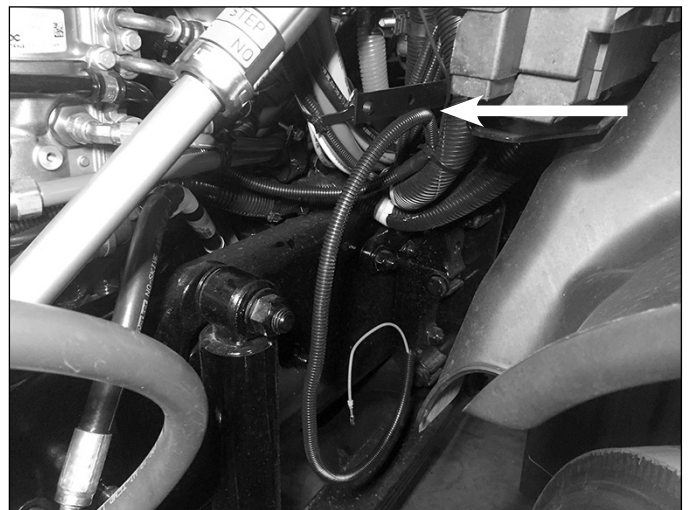

12VDC PRE-HEATER WIRING INSTRUCTIONS

Step 5

Locate the X57 connector and release the yellow handle to remove the connector.



Step 6

Remove the cover for the connector X57 by lifting up-wards on the tabs.

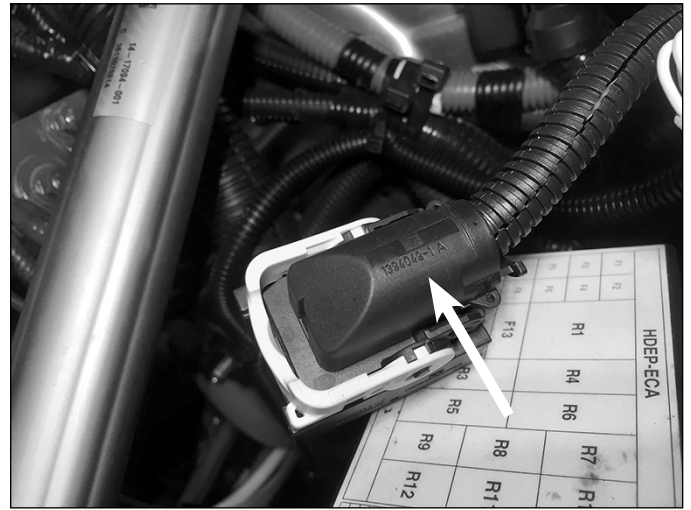

Step 7

Locate the cavity 15 on X57 and remove the cavity plug.



Step 8

Slide the yellow terminal lock towards the outside of the connector.

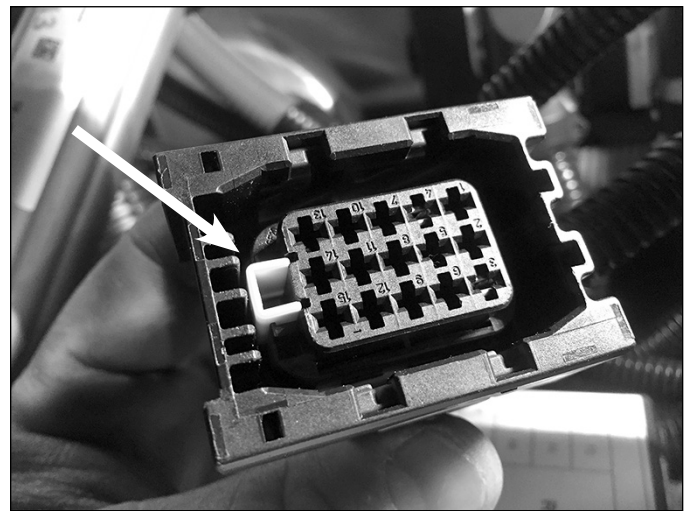

12VDC PRE-HEATER WIRING INSTRUCTIONS

Step 9

Insert the 12VDC pre-heater power wire into cavity 15 of the X57 connector.

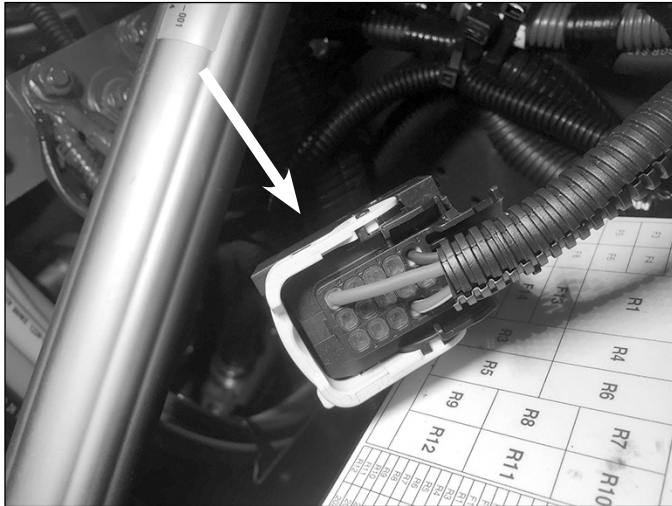

Step 10

Re-install the cover for X57 connector, push until tabs lock.



Step 11

Re-install the X57 to SAM Chassis Connector and lift handle to secure.



Step 12

Install the 20amp/35amp circuit breaker relay in the R1 location and the 20amp fuse in the F2 location.

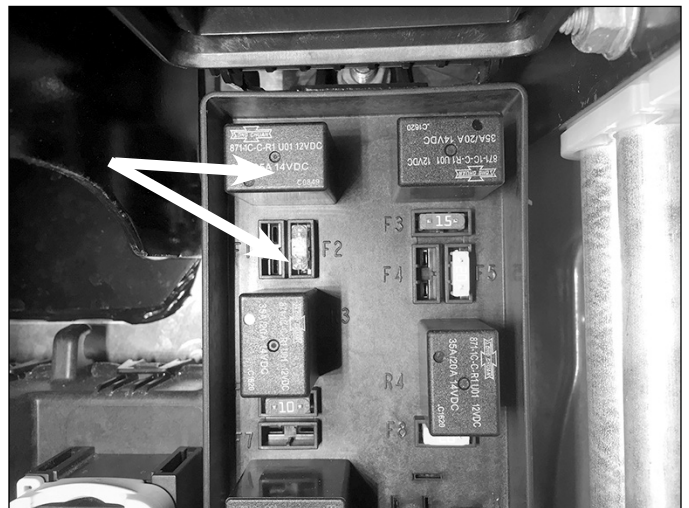

12VDC PRE-HEATER WIRING INSTRUCTIONS

Step 13

Mark the inside of cover showing the added circuits R1 and F2 with a red or yellow marker and re-install cover.

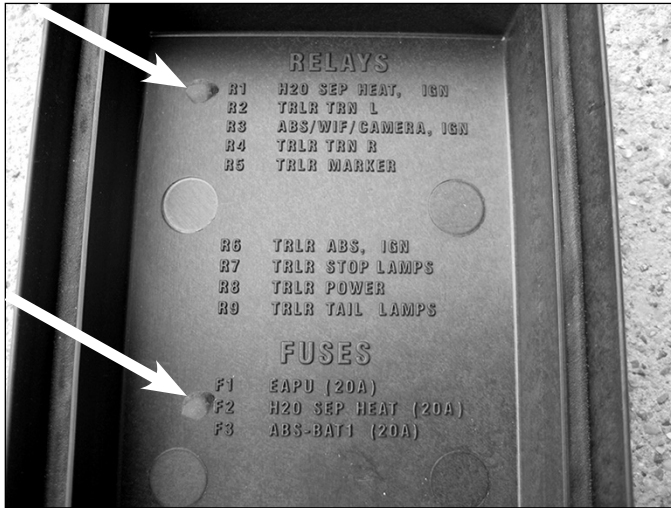

Step 14

Using an inductive DC amp meter, cycle the key to the on position and check for inrush current draw as shown.



VISUAL DIAGNOSTICS - AIR VS. VAPOR BUBBLES

There are two kinds of bubbles that may be visible at the fuel pump inlet of a diesel fuel system. The bubbles can be characterized as either air bubbles or vapor bubbles.

Air Bubbles

Air bubbles are caused by any air leak on the vacuum (suction) side of the fuel system from the fuel tank pick-up to, and including, the lift pump.

If there is an air leak in the fuel system, air bubbles will be present in the clear cover of the Fuel Pro follow “Diagnostic Procedures” for air leak diagnostics. If there are no bubbles present in the Fuel Pro cover and the engine continues to run rough, lopes or has a loss of power, there may be an air leak between the Fuel Pro outlet port and lift pump inlet. This type of air bubble can be seen if a sight tube is installed at the lift pump inlet. Air bubbles may also be visible in the fuel return (spill) hose out of the fuel gallery. These leaks are easily eliminated by checking and torquing the fuel fittings in the area of the leak.

NOTE 1: A quick procedure to determine if the air leak is between the fuel tank and the Fuel Pro is to remove the Fuel Pro inlet hose and route a new hose from the Fuel Pro inlet into a container of fuel or the fuel tank fill cap opening. Start the engine and check for bubbles.

If there are no air leak symptoms, but bubbles are present in a sight tube at the fuel lift pump inlet, they are most likely vapor bubbles.

Vapor Bubbles

All diesel fuel has some level of entrained air caused by the natural splashing that occurs in the fuel tank during normal vehicle or equipment operation. Vapor bubbles develop in the Fuel Pro because the pressure inside the Fuel Pro is lower than the atmospheric pressure in the fuel tank. Vapor bubbles can vary from champagne size up to ¼" in diameter. They may increase in size or volume as engine rpm increases. The lower pressure draws the entrained air/vapor out of the fuel and these bubbles will be visible as the fuel exits the Fuel Pro.

As the fuel enters the lift pump, it is pressurized and the bubbles are compressed back into the fuel. There will be no bubbles on the fuel return side of the system. These vapor bubbles will not affect the performance of the engine.

NOTE 2: An easy way to determine the difference between vapor and air bubbles is by temporarily removing the filter element from the Fuel Pro. Fill the cover with clean diesel fuel, replace the vent cap. Tighten the vent cap by hand until it clicks. Re-run the outlet fitting sight glass test. If there are no bubbles present in the sight glass then they were vapor bubbles. If bubbles are still present, they are air bubbles. If air bubbles still exist, re-run the test in NOTE 1 to eliminate the chassis plumbing as a variable.

There is no troubleshooting or repair procedure required for vapor bubbles. Vapor bubbles do not cause performance issues and will not be present after the lift pump.

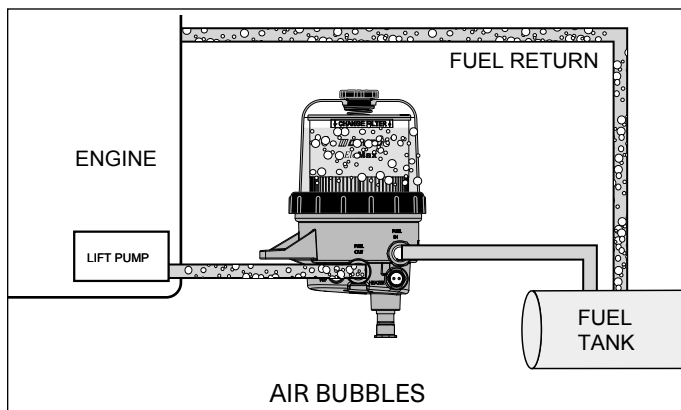

Figure 1

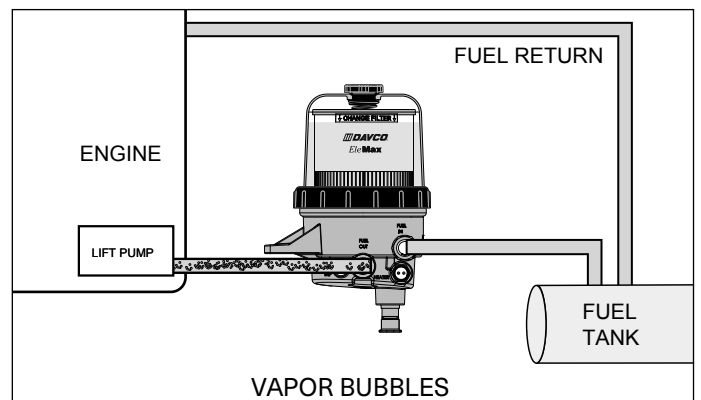









Figure 2

VISUAL DIAGNOSTICS WITH CLEAR COVER

<p>Fuel level is not at the top of the fuel filter. → Normal - Do not change the filter.</p>	
<p>Fuel level is at the top of the filter and appears to be full of wax. → Change the filter - Run the engine for a minimum of 25 minutes at idle. Do not run at full RPM.</p>	
<p>Bubbles are seen flowing in with the fuel. → Check all fittings and lines from the fuel tank to the Fuel Processor. Check lower and upper collar o-rings.</p>	
<p>Fuel drains back to the fuel tank when changing the fuel filter or draining separator. → Remove the check valve assembly. Clean or replace and retest. Check air leaks in the fuel system.</p>	
<p>Fuel level is at the top of the filter. Low power. → Change the filter at the first available opportunity.</p>	
<p>There is a power complaint and the fuel level is below the collar. → Check for a missing grommet at the lower end of the filter or missing/broken spring at top of filter.</p>	
<p>Water is noticed in the cover. → Drain the water.</p>	

DIAGNOSTIC PROCEDURES - AIR LEAKS

Every Fuel Pro is factory tested for leaks and is identified with a traceable number prior to shipment. Most field issues associated with leaks are related to loose fittings. These leaks are easily eliminated by checking and torquing the fuel fittings in the area of the leak. Some fittings may also require the application of liquid or paste type thread sealant.

All suction side fuel filters experience bubbles. It is normal to see champagne size bubbles in the Fuel Pro cover, at the Fuel Pro outlet or at the lift pump.

IN ORDER TO RETURN A FUEL PRO FOR EVALUATION, THE FOLLOWING PROCEDURES/TESTS MUST BE COMPLETED BEFORE REQUESTING A DAVCO RGA (RETURN GOODS AUTHORIZATION) NUMBER.

- I. Air bubbles will be visible in the clear cover of the Fuel Pro if the leak originates between the fuel tank and the Fuel Pro. The following is a quick test to isolate the air leak source.
 - A. Remove the Fuel Pro inlet hose.
 1. Install a jumper hose from the Fuel Pro to the fuel tank (through the fill cap) or to a container of fuel.
 2. Start the engine. If this eliminates the air bubbles, the air source is at the fuel tank fittings or hose connections.
 3. Tighten all fittings and connectors. Retest.
 - a. If air bubbles persist, the air source is on the Fuel Pro side of the system:
 - i. Tighten all fittings on the Fuel Pro.
 - ii. Loosen the collar until it spins freely. Apply downward pressure on the top of the cover and rotate the collar until contact. Use a DAVCO wrench (if necessary) to tighten the collar three additional ribs.
 - b. If the drain valve is suspected, install a plug in place of the drain valve (for test purposes only).
4. If air bubbles persist, test as follows:
 - a. Remove the Fuel Pro from the chassis.
 - b. Plug the fuel outlet port. Do not remove filter, cover/collar, vent cap, drain valve and/or check valve. If the Fuel Pro is equipped with a pre-heater, do not remove the pre-heater.
 - c. Apply 15 PSI of air pressure at the fuel inlet. Immerse the Fuel Pro in a tank of water and look for air bubbles.
 - d. Correct the source of the air leak and retest.
- II. Bubbles Not Visible: If there are symptoms of sucking air (indicated by engine loping/rough running performance/power loss, etc.) and there are no bubbles in the clear cover, the air leak is either at the Fuel Pro outlet fitting, vent cap o-ring, the lift pump inlet connection, or the fuel hose/connections to the lift pump. Inspect and tighten fittings as needed.
- III. Excessive Restriction: If the fuel level is at the top of the filter, replace the fuel filter. The Fuel Pro will not cause excess system restriction if the fuel level is below the top of the filter. The only exception is if the grommet is not installed in the bottom of the filter element.
 - A. Loss of Prime: When air is introduced into the fuel system, (i.e. draining water from the Fuel Pro or when replacing the fuel filter) a check valve is needed to keep the fuel system primed from the Fuel Pro back to the fuel tank. A check valve is standard with every Fuel Pro.
 - B. To test for proper check valve operation, put a drain pan under the Fuel Pro, remove the fuel inlet hose and open the vent cap. Fuel should not flow out of the Fuel Pro although slight seepage of fuel is normal. If fuel flows out of the unit, follow the check valve testing procedures. To test for proper check valve operation, place a drain pan under the Fuel Pro, remove the fuel inlet hose and open the vent cap. Fuel should not flow out of the Fuel Pro, although slight seepage of fuel is normal. If fuel flows out of the Fuel Pro fuel inlet, "Check Valve Diagnostics" on page 20.

DIAGNOSTIC PROCEDURES - CHECK VALVE AND HEATER TESTING

Check Valve Diagnostics

To test for proper check valve operation, remove the fuel inlet hose and open the vent cap. Fuel should not flow out of the Fuel Pro, although a slight seepage of fuel is normal. If fuel drains back to the fuel tank, remove the check valve assembly at the fuel inlet fitting.

1. Open the vent cap. Open the drain valve by turning one to one and a half revolutions. Drain the Fuel Pro completely. Close the drain valve.
2. Use a back-up wrench to hold the check valve body and remove the fuel hose from the inlet of the Fuel Pro.
3. Remove and disassemble the check valve assembly.
4. Clean and inspect the check valve body. Replace the check valve body if any cuts, grooves or nicks are evident or if the ball seat is not smooth.
5. Inspect the check valve spring and spring retainer. If the spring or spring retainer is broken or if the check ball has groves, nicks or is out of round, replace with a check valve service kit. Otherwise, clean and reassemble the check valve assembly. The spring retainer snaps into a groove in the check-valve body.
6. Replace the check valve assembly into the body and torque to 30-55 ft-lb.
7. Connect the fuel inlet hose, using liquid or paste type thread sealant.
8. Prime the fuel system, start the engine and check for any fuel leaks.

PTC Pre-heater/Overnight Heater Testing Procedures

⚠ **Do not energize pre-heater/heater outside of the Fuel Pro. Caution! Very hot.**

Equipment Needed: A precision low resistance ohm meter capable of measuring with accuracy to two decimal places.

1. Disconnect the harness from the pre-heater or overnight heater.
2. Connect the ohm meter leads to the pins of the pre-heater or overnight heater. Use the following to determine whether the resistance value is in the acceptable range.

PRE-HEATER	WATTS	RESISTANCE RANGE (OHMS)
12VDC (PTC)	195 W	0.4 to 0.6 @ 77°F (25°C)
24VDC (PTC)	195 W	2.0-3.0 @ 77°F (25°C)
12VDC (PTC)	155W	0.95 to 1.2 @ 77°F (25°C)

OVERNIGHT HEATER	WATTS	RESISTANCE RANGE (OHMS)
120VAC	75 W	173 to 203 @ 77°F (25°C)

FILTER CHANGE PROCEDURE

Recommended Filters

FILTERS (AVAILABLE THROUGH OEM DISTRIBUTORS)	
DDC	A0000905051
Fleetguard	FS20083

1. Turn off the engine. Remove the vent cap and dispose of the o-ring. Clean the threads of the vent cap and on the top of the cover. Set the vent cap aside.
2. Open the drain valve one to one and a half revolutions and drain the fuel completely from the unit, then close the drain valve.

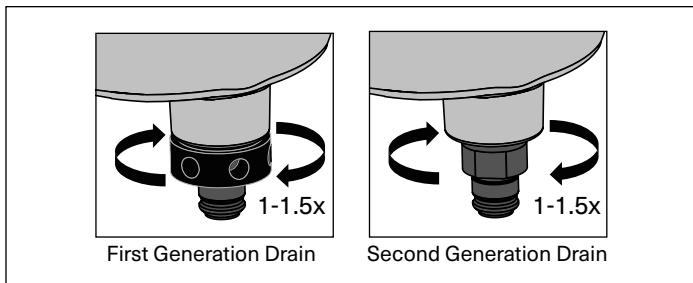

3. Using the Collar Wrench, loosen the collar.
4. Remove the clear cover and collar from the Fuel Pro. Discard the cover o-ring and install a new o-ring (supplied with the filter) on the cover. Clean the threads on the collar and the body.
5. Install the new o-ring on vent cap (supplied with the filter).
6. Remove the filter element by pulling upward.

7. Install the new filter element. Position the filter element so the key is lined up with the keyway on the separator plate of the housing. Use the arrow on the top of the endplate to align the filter. Ensure the filter element is fully seated by firmly pushing on the endplate. The filter should not rotate freely.

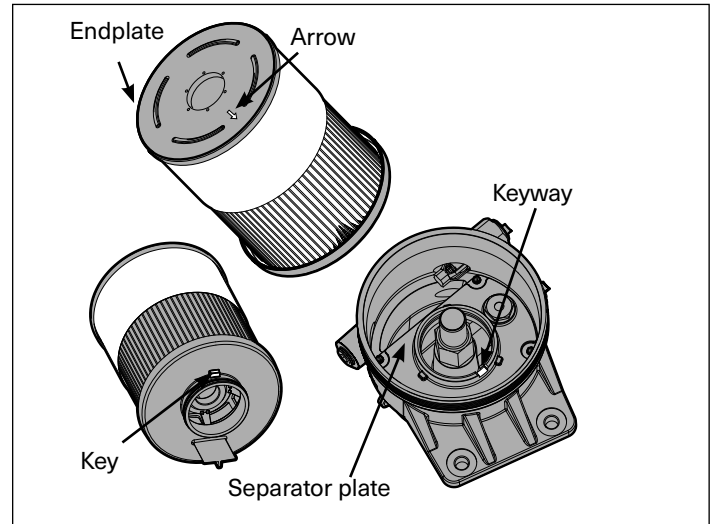

8. After checking to make sure the new o-ring seal is seated correctly on the base of the cover, install the cover and collar.
9. Apply downward pressure on the top of the cover and rotate the collar until contact.

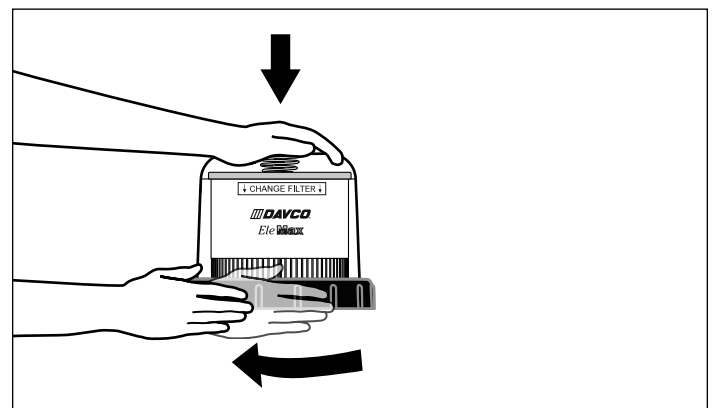

PREVENTATIVE MAINTENANCE

10. Use a DAVCO wrench to tighten 3 additional ribs.

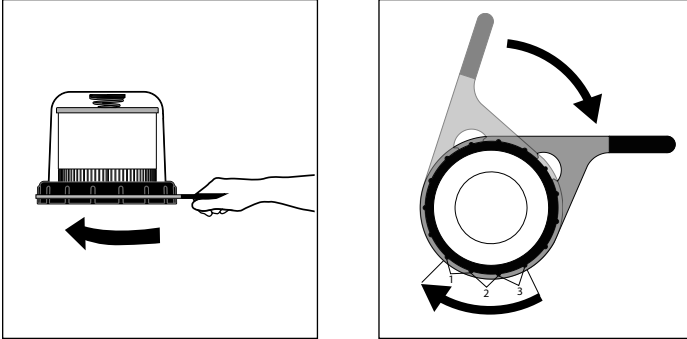

11. Prime the unit by filling the clear cover with clean diesel fuel until it reaches the top of the filter.

12. Install the vent cap. Tighten the vent cap by hand until it clicks.

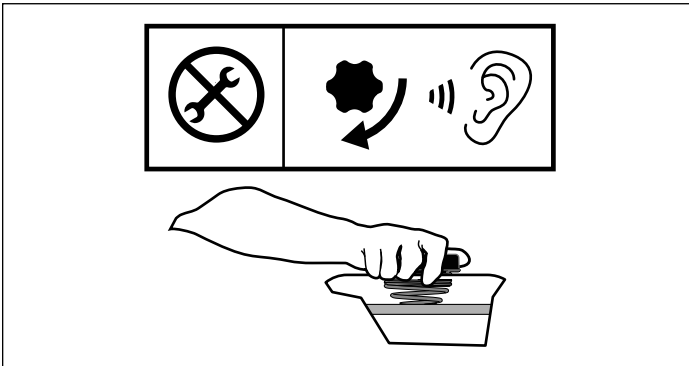

13. Start the engine. When the lubrication system reaches its normal operating pressure, increase engine RPM to high idle for one to two minutes.

14. After the air is purged loosen the vent cap until the fuel level drops to just above the collar. Tighten the vent cap by hand until it clicks.

Preventative Maintenance

Environmental Concerns and Seasonal Maintenance

- Steam clean the Fuel Pro with fresh water regularly to keep corrosive salt or dirt from building up on the housing, cover and collar.
- Extreme winter or salt corrosion environments may require lubrication of the collar with anti-seize lubricant every 180 days.

Weekly water drains

1. Turn off the engine and remove the vent cap.
2. Place a suitable container under the Fuel Pro and open the drain valve.
3. Collected water will flow into the container. When fuel begins to flow out the drain, close the drain valve. Drain the least amount of fuel as possible.
4. Install the vent cap and tighten it by hand until it clicks.
5. Start the engine and raise the RPM for one minute to purge the air from the system.

During each filter change

- Change the o-rings on the cover and vent cap (included with the service filter kit).

Annual inspection



- Inspect all electrical connections for corrosion.
- Inspect all fuel fittings for leaks.
- Inspect the Fuel Pro for damage or signs of leaks.

SERVICE PROCEDURES - BYPASS VALVE**Bypass valve Installation**

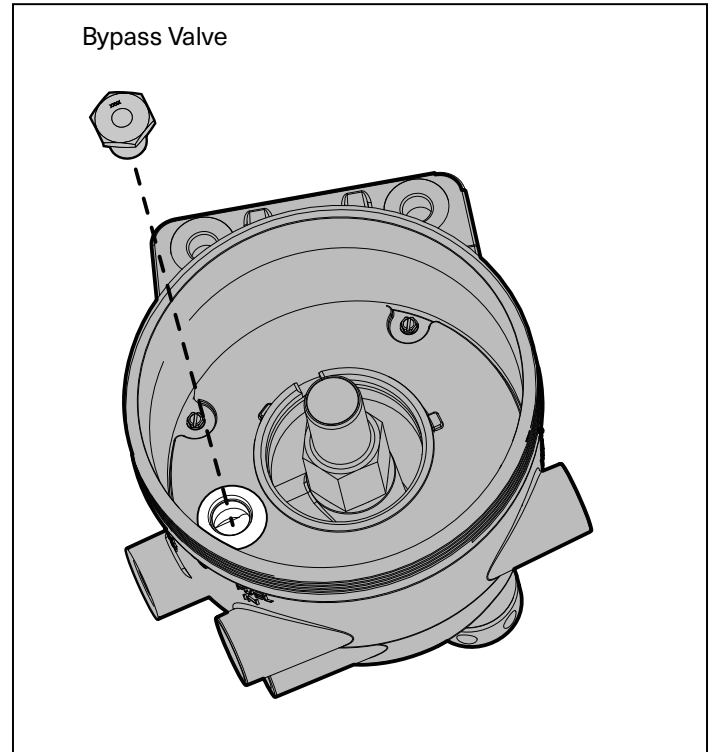
1. Remove the vent cap. Open the drain valve by turning one to one and a half revolutions. Drain the Fuel Pro completely. Close the drain valve.
2. Remove the collar (using a DAVCO wrench) then remove the clear cover.
3. Remove the filter.
4. Using a clean shop rag, clean the cover, the collar and the threads on the Fuel Pro body.
5. Flush the inside of the Fuel Pro body with clean diesel fuel to clear it of any debris.
6. Remove the bypass valve assembly and discard.
7. Remove the protective cap from the replacement bypass valve assembly.
8. Install the replacement bypass valve assembly into the Fuel Pro body (torque to 20 ft-lbs).
9. Install the filter. Refer to the section "Filter Change" to ensure that the filter is aligned correctly.
10. Apply downward pressure on the top of the cover and rotate the collar until contact.
11. Use a DAVCO wrench (if necessary) to tighten 3 additional ribs.
12. Prime the unit by filling the clear cover with diesel fuel until it reaches the top of the filter.
13. Install the vent cap. Hand tighten until it clicks.
14. Start the engine and run for one minute. Slowly open the vent cap and allow the fuel level to drop to about one inch above the collar.
15. Hand tighten the vent cap until it clicks.

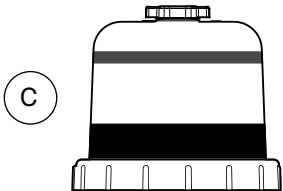

SERVICE PART NUMBERS

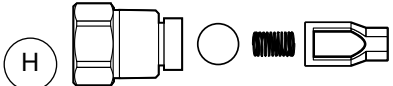
SERVICE PARTS AND KITS		
A	DVC 240023DAV	Vent Cap Service Kit (vent cap and o-ring)
B	DVC 482044	Cover Service Kit (Collar, Spring, Vent Cap and Vent Cap O-ring - Collar o-ring not included)
C	DVC 482046DAV	Cover with Red Stripe and Black Band (Collar, Spring, Vent Cap and Vent Cap O-ring, Collar o-ring)
		
D	DVC 380056	Filter Spring
E	DVC 482003	Collar
F	DVC 482022	O-Ring Service Kit (Vent Cap/Cover)
G	DVC 101132	Check Valve Service Kit (Ball, Spring, and Retainer)
		
H	DVC 482012	Check Valve Assembly (M22) (Body and Check Valve Service Kit)
		
I	DVC 482010SVC	Bypass Valve
J	DVC 482017	Collar Wrench
K	DVC 020909	Plug
L	DVC 485022DAV	Quick Connect Drain Valve - Includes: valve body, retaining ring (N), both seals (O), drain valve and protective cap (P)
M	DVC 485025DAV	Retaining Ring
N	DVC 485021DAV	Drain Valve Seal Service Kit
O	DVC 102712DAV	Drain Valve Dust Cap
<p>Pre-heater, Overnight Heater, and Water in Fuel Sensor (WIF) information is on the next page.</p>		

PARTS ARE AVAILABLE THROUGH
DAIMLER TRUCKS NORTH AMERICA

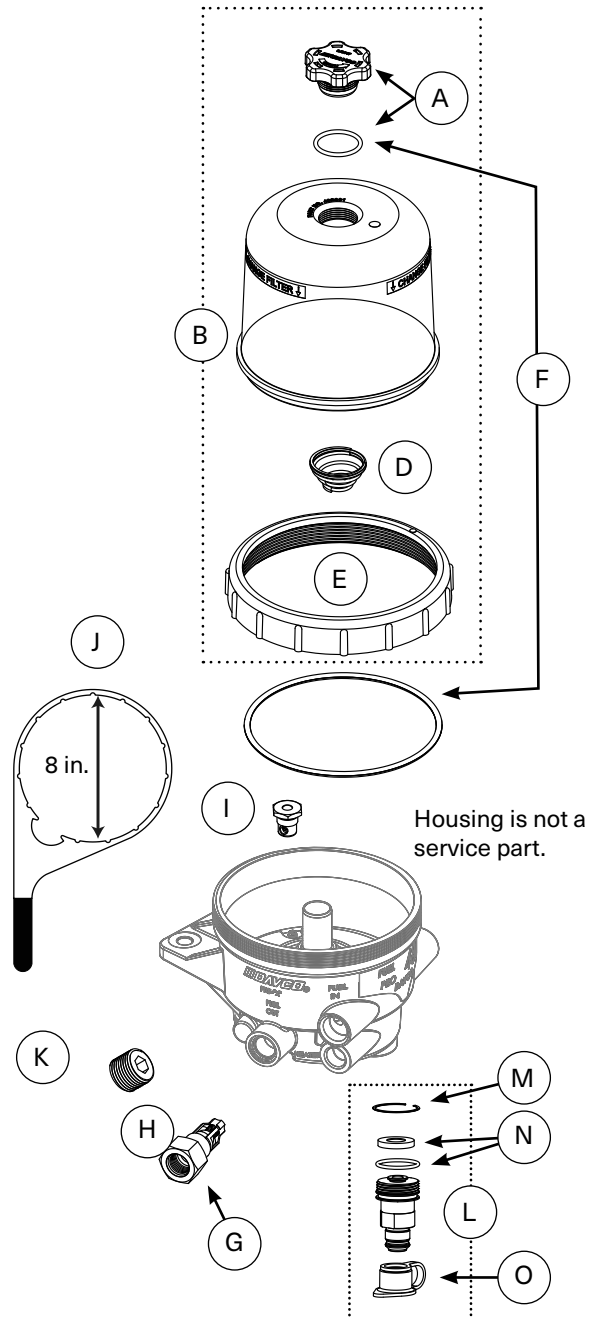

SERVICE PART NUMBERS

PRE-HEATER PARTS

DVC 103528	12VDC 195W PTC Pre-heater, Metri-Pack Connector, ½"-14 NPTF Threads, Harness Length 19.81"	
DVC 103594	12VDC 155W PTC Pre-heater, Metri-Pack Connector, ½"-14 NPTF Threads, Harness Length 24.50"	
102376DAV	Pre-heater Chassis Harness, Metri-Pack Connector, Wire Lengths 24" and 180"	

OVERNIGHT HEATER PARTS

DVC 102145	120VAC 75W Overnight Heater, ½"-14 NPTF Threads	
DVC 102015	120VAC Overnight Heater "Y" Cord, Cord lengths: 84" and 120"	
DVC 101868	120VAC Overnight Heater Straight Cord, Cord length: 72"	

WATER-IN-FUEL (WIF) SENSOR

DVC 102770	Two Pin WIF, Metri-Pack Connector, ½"-20 UNF Threads, Harness Length 6.50" (Freightliner)	
------------	---	--

WARRANTY POLICY

Please review DAVCO's Product Warranty terms and conditions carefully before installing and/or using a DAVCO product.

Diesel Pro® 243 and 245, Fuel Pro® 382, 482, 483, 485, 487 and 488, Industrial Pro®, Pro-Chek®, Sea Pro®

DAVCO Technology, LLC warrants these products to be free of defects in material and workmanship for five years, 500,000 miles or 10,000 hours (whichever comes first) and electrical parts for two-years, 200,000 miles or 4,000 hours (whichever comes first) from the purchase date*.

Shop Pro®

DAVCO Technology, LLC warrants the Shop Pro (except for the motor) to be free of defects in material and workmanship for two years from the date of purchase. The Shop Pro motor is warranted for one year from date of purchase.

REN Products, EyeMax®, and Fuel Pro® 384

DAVCO Technology, LLC warrants these products to be free of defects in material and workmanship for two-years or 200,000 miles (whichever comes first) from the purchase date.

By installing and/or using the product, you agree to be bound by the following:

This Warranty does not apply to:

- Failure or inadequate performance due to improper installation, misuse, misapplication, faulty installation, alteration/modification, poor maintenance, neglect, accident, or conditions resulting from actions outside DAVCO's control, including but not limited to the use of contaminated, corrosive, and unapproved fluids.
- Downtime, loss of use, loss of profits or income, loss of capital, cost of substitute equipment, living expenses, claims by purchaser's customers or other third parties, or other incidental, special or consequential damages.
- Attachments, accessory items, and parts not manufactured or distributed by DAVCO.
- Any aftermarket or OEM component not approved specifically to work with a DAVCO manufactured product
- Product that has been installed with aftermarket parts or altered or modified in any way.
- Normal wear and tear, abuse, vandalism, acts of God, improper storage or handling, disasters such as flood, fire, or war, failure to operate, maintain or repair in accordance with instructions, or failure to repair the vehicle into which the product is installed in accordance with the vehicle manufacturer's instructions or common maintenance practices.

This warranty is the sole warranty made by DAVCO. DAVCO makes no other warranties, expressed or implied, of merchantability or fitness for a particular purpose.

In the unlikely event of a defective product, DAVCO will either rework the defective product or replace it at DAVCO's discretion. If you feel you have a warrantable issue, contact DAVCO at 800-328-2611 for a Return Goods Authorization (RGA) number **. An RGA number is required prior to the return of any product.

* Purchase Date: The date of the first retail purchase of a new vehicle or piece of equipment from the OEM dealer or factory. For "Over the Counter" purchase: The date of sale to the first retail customer.

**Products submitted for Warranty consideration will be inspected by DAVCO personnel. Re-work or replacement will be based on DAVCO's Warranty procedure and/or the results of their evaluation. DAVCO's Warranty Program does not in any way constitute a product guarantee.



A Clarience Technologies Company

PARTS RETURN POLICY

Parts Return General Policy

A Return Goods Authorization (RGA) must be obtained from DAVCO prior to returning any products. Returns may be accepted under the following circumstances:

Order Shipping Error: A credit against the original invoice, including freight charges for both ways will be issued for returns in which DAVCO inadvertently shipped incorrect quantity or product.

Overstock: Returns for ordering more product(s) than required, or incorrect part(s), will be accepted within 60 days from the date of purchase. Proof of purchase will be required, i.e.: original invoice/delivery receipt. These types of return(s) are subject to a minimum restock fee of 40% or \$40.00, whichever is higher. Additional restock fees may apply. Product(s) will be inspected for "like new" condition and additional costs will be the responsibility of the customer. No obsolete parts may be returned.

Freight charges for return(s) will be the responsibility of the customer.

