

FUEL PRO[®] 499



DAVCO FUEL PRO 499 is an all-in-one fuel filter, water separator, and fuel pre-heater for heavy duty on-highway diesel engines with flow rates up to 180 gallons per hour. The Fuel Pro 499, with an optional return fuel heat, 12/24V pre-heater, 120V overnight heater and water-in-fuel sensor will keep the engine running in any weather conditions.

Three layer filter design, with filtration to 10 microns, provides enhanced water separation capabilities for ultra-low sulfur diesel fuel with low interfacial tension.

Applications

- On/Off Highway heavy duty diesel with flow rates up to 180 gph

Models and Options

- Base Model - Un Heated
- Electric Heat: Select one or both
 - 12VDC or 24VDC Pre-heater
 - 120VAC Overnight heater
- Water-In-Fuel (WIF) sensor
- Fluid Heat Option: Return Fuel

Typical Installation

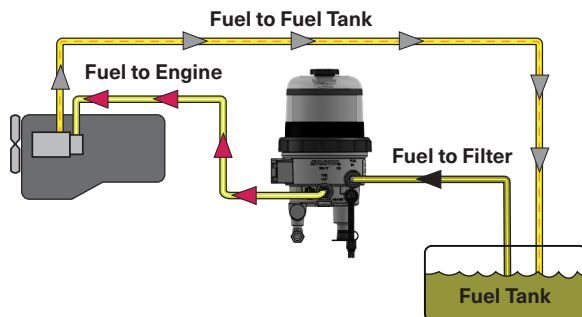

Filter Technology

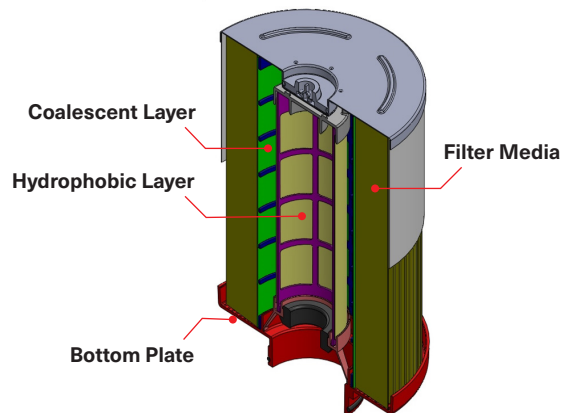

A **Clariance Technologies** Company

DAVCO Technology, LLC

1600 Woodland Drive, Saline, MI 48176-1629

800-328-2611

customerservice@davco.com

www.davco.com

FUEL PRO® 499

Specifications

Height, Overall,	15.07 in. (382.8 mm)
Depth, Overall	8.85 in. (224.8 mm)
Width, Maximum	9.0 in. (228.6 mm)
Weight, Dry	Approx. 15 lbs
Minimum Service Height	4 in. (101.6 mm)
Max Fuel Flow	180 gph
Pre-heater	12VDC (150W) or 24VDC (135W)
Overnight heater	120VAC, 75W

Filtration Performance (10 micron at 174 GPH)

Micron	10
Coarse water removal (%)	>99%
Emulsified water removal (%)	>93%
% Emulsified water removal (end of life filter)	>80%
Dirt holding capacity (grams)	150

Port Interface

Fuel In	VOSS NS-12
Fuel Out	VOSS NS-12

Dimensions

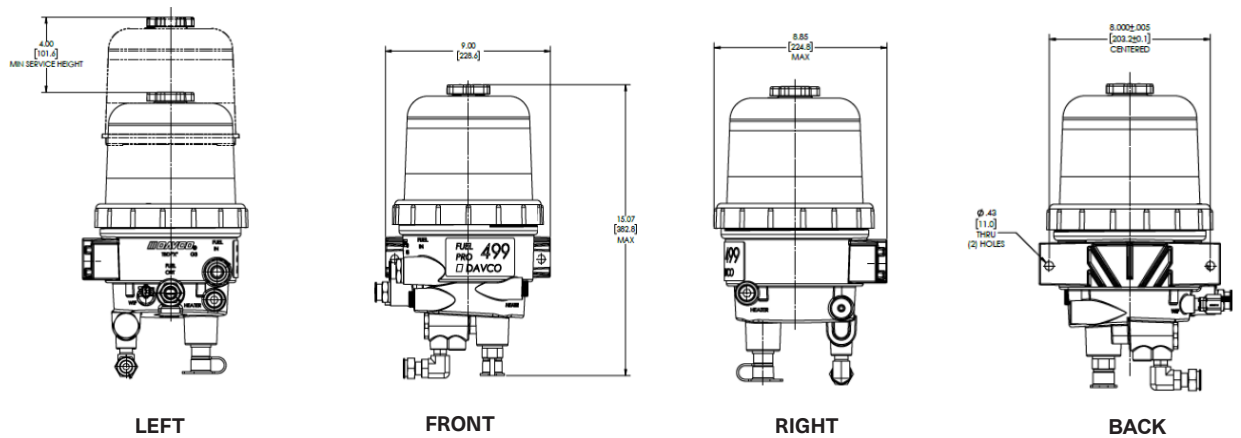

Part Numbers for Navistar Fuel Pro 499

Sales Code	DAVCO P/N	Description
0015LNV	499151LLNAVRE-10	Fuel Pro 499 w/ Water-In-Fuel Sensor
0015LNW	499153LLNAVRE-10	Fuel Pro 499 w/12V Pre Heater and Water-in-Fuel Sensor
0015LNX	499161LLNAVRE-10	Fuel Pro 499 w/120V Overnight Heater and Water-in-Fuel Sensor
0015LNY	499163LLNAVRE-10	Fuel Pro 499 w/120V Overnight Heater, 12V Pre Heater and Water-in-Fuel Sensor

Replacement Filter:

Fleetguard Part Number: FS203864

Navistar Part Number: 2525984C1