

# DIESEL PRO® 245

## PRODUCT DATA SHEET

The **DIESEL PRO® 245** is an all-in-one fuel filter, water separator, and fuel pre-heater for medium duty diesel engines with flow rates up to 60 gallons per hour.

With an optional pre-heater or overnight heater and water-in-fuel sensor, the Diesel Pro® 245 will keep the engine running in any weather conditions. Three layer filtration provides enhanced water separation capabilities.

Seeing is Believing® functionality and the clear cover on top provides enhanced fuel system troubleshooting and a clear indication of when to change the fuel filter.

### Applications

- Diesel engines with flow rates up to 60 gph

### Options

- Base model: unheated
- Heating options:
  - 12VDC Pre-heater: uses ignition switch to heat fuel prior to running the engine
  - 120VAC Overnight heater: prevents gelling while parked overnight
- Water-In-Fuel (WIF) sensor

### Filter Technology

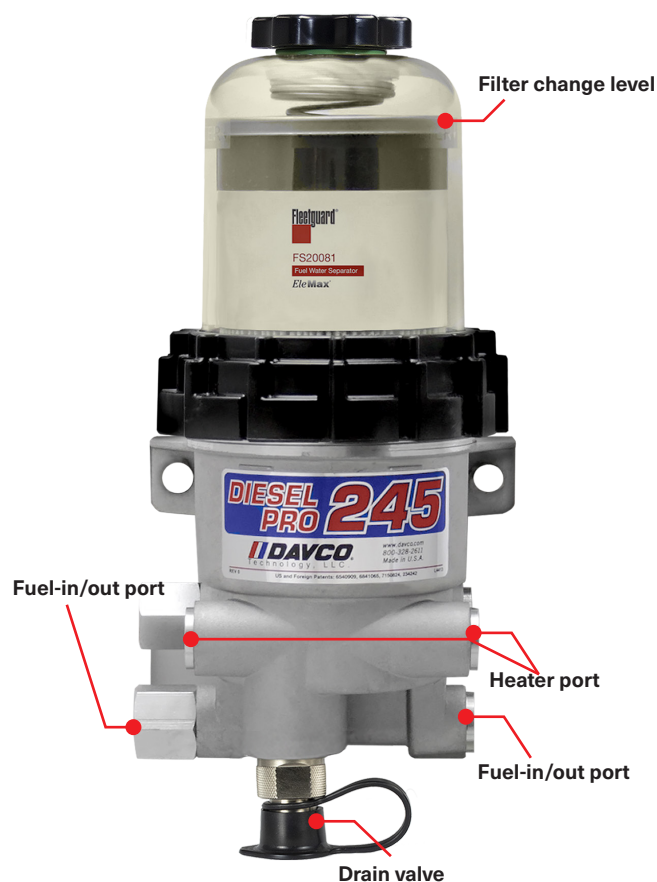
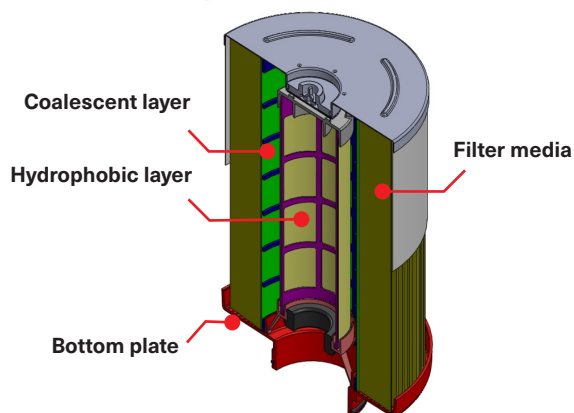

### Benefits

- Seeing is Believing® - see when NOT to change your filter
- Protects diesel engines from contaminants
- Reduces maintenance downtime
- Visual troubleshooting
- Environmentally friendly filter change
- Simple filter priming for easier starts
- Biodiesel up to B20 compatible



A Clariance Technologies Company

800-328-2611

customerservice@davco.com

www.davco.com

F3515 REV FJ Updated on 04/27/2026

# DIESEL PRO<sup>®</sup> 245

## Specifications

Height, overall	13.37 in. (339.5 mm)
Depth, overall	5.84 in. (148.3 mm)
Width, maximum	6.2 in. (158 mm)
Weight, dry	7.7-8.5 lbs.
Filter service clearance, minimum	3.5 in. (88.9 mm)
Fuel flow, maximum	60 gph
Electric pre-heater	12VDC 150W
Overnight heater	120VAC, 95 W, .65 A

Replacement filters:

- Fleetguard part number: FS20081
- Detroit Diesel part number: A0000904851

## Dimensions

Dimensions are in inches [millimeters]

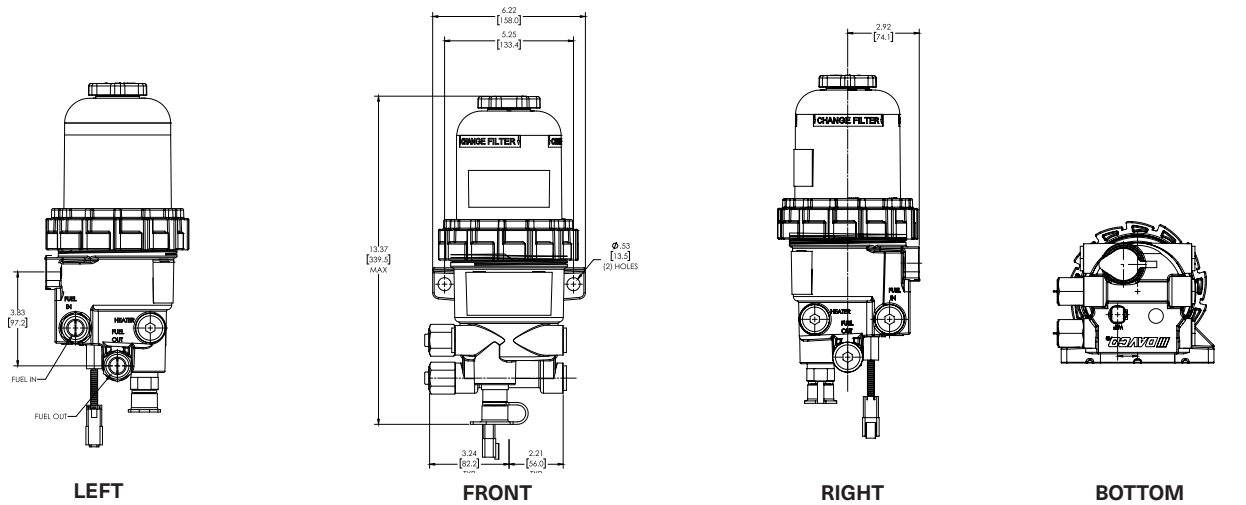

## Seeing is Believing<sup>®</sup>



When new, the fuel level in the filter will be very low with minimal restriction. As the filter is used, contaminants collect on the filter from the bottom up. Fuel rises on the filter indicating remaining filter life.



Fuel level increases in clear cover. As contaminants collect on the filter, the fuel rises to a non-contaminated section of the filter, providing optimal filtration while maintaining lowest restriction.



Fuel level at filter wrap level. Even though the fuel level is now more than half of the filter element, the fuel is still flowing through clean media at minimal restriction levels. The filter still has significant life remaining.



The filter element is now completely covered by fuel. At this point, all of the media's surface area is utilized. Restriction is increasing and the filter element should be changed at the next scheduled maintenance interval.

## DAVCO Technology, LLC

All statements are based on OEM fuel quality requirements. Contact your DAVCO RSM for OEM specific warranties.

© 2025 DAVCO Technology, LLC. DAVCO is a subsidiary of Clariance Technologies. All rights reserved.

