

FUEL PRO[®] 385

PRODUCT DATA SHEET

The **FUEL PRO[®] 385** provides filtration and fuel water separation for diesel engines with flow rates up to 180 gallons per hour.

The Fuel Pro[®] 385 is designed specifically for Daimler Trucks, with an optional pre-heater, overnight heater and water-in-fuel sensor.

Three layer filter design, with filtration to 10 microns, provides enhanced water separation capabilities for ultra-low sulfur diesel fuel with low interfacial tension.

Applications

- Daimler Trucks with flow rates up to 180 gph

Options

- Base model: unheated
- Heating options:
 - 12VDC Pre-heater: uses ignition switch to heat fuel prior to running the engine
 - 120VAC Overnight heater: prevents gelling while parked overnight
- Water-In-Fuel (WIF) sensor

Benefits

- Seeing is Believing[®] - see when NOT to change your filter
- Protects diesel engines from contaminants
- Reduces maintenance downtime
- Visual troubleshooting
- Environmentally friendly filter change
- Simple filter priming for easier starts
- Biodiesel up to B20 compatible

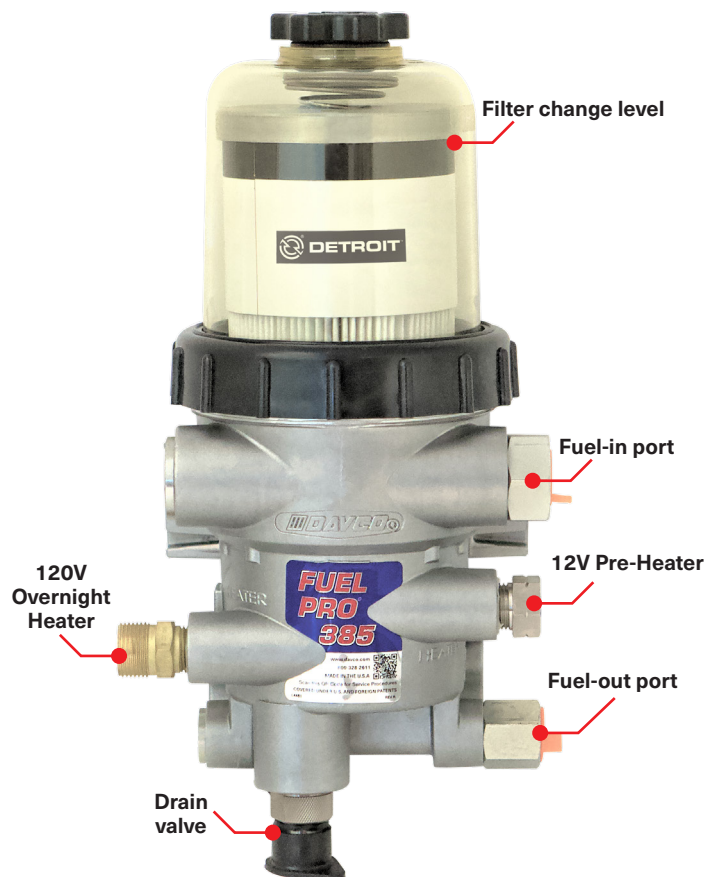

Filter Technology

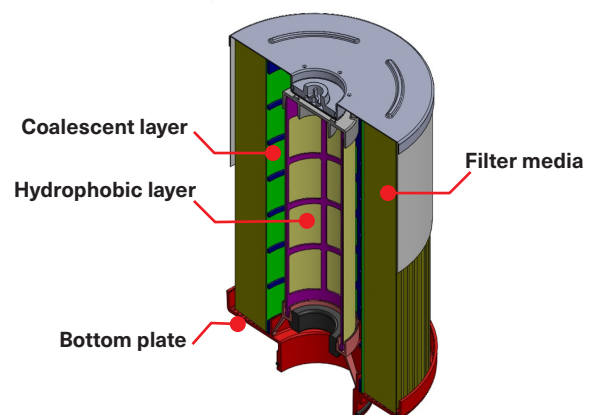

A Clariance Technologies Company

800-328-2611

customerservice@davco.com

www.davco.com

F3513 REV G | Updated on 05/20/2026

FUEL PRO® 385

Specifications

Height, overall	15.39 inches (390.8 mm)
Depth, overall	6.58 inches (167.1 mm)
Width, maximum	7.19 inches (182.63 mm)
Weight, dry	Approx. 8-12 lbs
Minimum service height	3.5 inches (38.1 mm)
Max fuel flow	180 gph
Pre-heater	12VDC, 150W
Overnight heater	120VAC, 95W

Filtration Performance (10 micron at 174 GPH)

Emulsified water removal	SAE J1488 is 96.9%
Dirt holding capacity	89 grams

Port Interface

Fuel-in	M22x 1.5-6H
Fuel-out	M22x 1.5-6H

Dimensions

Dimensions are in inches [millimeters]

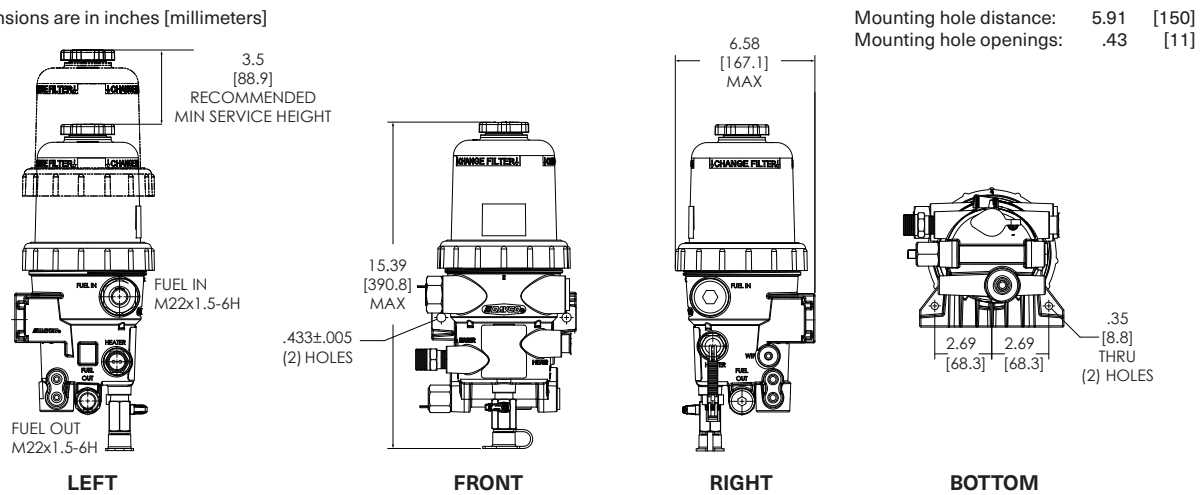

Part Numbers

DAVCO PART NUMBER	DTNA PART NUMBER	FUEL IN/FUEL OUT	OPTIONS
385150LLFTL-10	03-44726-000	Left/Left	Unheated
385150RRFTL-10	03-44726-006	Right/Right	Unheated
385152LLFTL-10	03-44726-001	Left/Left	12V Pre-heater
385152RRFTL-10	03-44276-007	Right/Right	12V Pre-heater
385162LLFTL-10	03-44726-002	Left/Left	12V Pre-heater and 120V overnight heater
385162RRFTL-10	03-44726-008	Right/Right	12V Pre-heater and 120V overnight heater
386151LLFTL-10	03-44726-003	Left/Left	Water-in-fuel sensor
386151RRFTL-10	03-44726-009	Right/Right	Water-in-fuel sensor
386153LLFTL-10	03-44726-004	Left/Left	12V Pre-heater and water-in-fuel sensor
386153RRFTL-10	03-44726-010	Right/Right	12V Pre-heater and water-in-fuel sensor
386163LLFTL-10	03-44726-005	Left/Left	12V Pre-heater, 120V overnight heater, water-in-fuel sensor
386163RRFTL-10	03-44726-011	Right/Right	12V Pre-heater, 120V overnight heater, water-in-fuel sensor

Replacement filter:

- Detroit Engine: FS20175 / A0000385007
- Cummins Engine FS20194

DAVCO Technology, LLC

All statements are based on OEM fuel quality requirements. Contact your DAVCO RSM for OEM specific warranties.

© 2025 DAVCO Technology, LLC. DAVCO is a subsidiary of Clariance Technologies. All rights reserved.